

5 Biodiesel Fuel Modeling

This section describes each phase of the life cycle for biodiesel production. Data and assumptions are described in the following sections:

- **5.1 Soybean Agriculture:** This section outlines the boundaries of this study, i.e., which data are included and omitted. This refers to the physical and geographic assumptions, as well as to the exclusion of secondary sources of data such as the production of capital equipment and data with high uncertainties.
- **5.2 Soybean Transport to Crusher:** This section describes the process flows associated with transporting soybeans to regional crushers.
- **5.3 Soybean Crushing:** This section explains how soybean crushing was modeled in the analysis. It includes assumptions and descriptions of process flows for soybean crushing.
- **5.4 Soybean Oil Transport:** This section explains how soybean oil and the biodiesel production and distribution industries are organized. It also includes assumptions and descriptions of process flows associated with soybean oil transportation.
- **5.5 Soybean Oil Conversion:** This section describes the modeling of soybean oil conversion to biodiesel.
- **5.6 Biodiesel Transport:** This section includes assumptions and descriptions of process flows associated with biodiesel transportation.

5.1 Soybean Agriculture

The agriculture part of this LCI study involves identifying the complete environmental flows associated with soybean production. This includes the amounts of chemicals and fuels used on the farm and their associated emissions, as well as the manufacturing, packaging, and processing of the inputs used to grow soybeans. For example, the energy required to mine, process, and transport potash fertilizer to the field is estimated. Also, the environmental flows and energy requirements involved in making and transporting pesticides, seed, and all other farm inputs are accounted for. These upstream environmental flows are combined with the flows associated with the actual soybean growing and harvesting to calculate the total emissions associated with soybean agriculture.

Figure 42 describes the modeling of soybean agriculture within the context of this LCA study.

The soybean agriculture block shown in Figure 42 represents the actual field or farm where soybeans are grown. The remaining 10 blocks represent the upstream flows associated with production of the agricultural inputs used to produce soybeans.

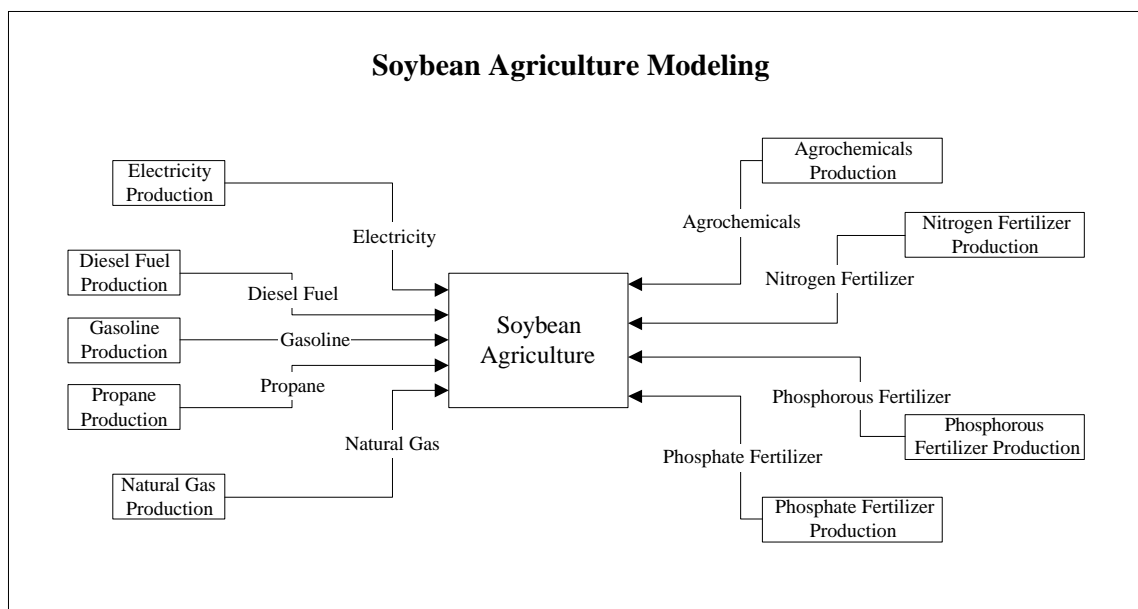

Figure 42: Soybean Agriculture System Modeling

5.1.1 Soybean Agriculture General Modeling Assumptions

The LCI models an agricultural system using current practices in agriculture. We assume that producing biodiesel from soybeans does not alter this baseline, i.e., near-term biodiesel production is too small to have any significant effect on soybean production, prices, or resource allocation. Soybeans are generally rotated with other crops, such as corn. Crop rotations help maintain soil moisture and fertility, reduce farm-level demand for fertilizer (Lin et al. 1995), and control insects, diseases, and weeds. However, our analysis is limited to a single growing season and adjustments related to the rotation sequence are *not* factored into input usage.

Another modeling assumption is made regarding plant uptake of CO₂. Plants use solar energy to fix carbon from CO₂ during photosynthesis. Soil insects (e.g., worms, mites, and centipedes) that feed on plant material or on other animals consume the biomass carbon. They eventually die and are added to the soil with the waste material of animals. All forms of dead organic materials are attacked by decomposers, mainly bacteria and fungi. Through enzymatic digestion, the carbon is returned to the atmosphere as CO₂ and energy is released as heat. Without decomposers to release fixed carbon, the atmosphere would become depleted of CO₂, life would cease, and the cycle would stop (Foth 1984).

In a sustainable agricultural system, there is no net CO₂ flux to the atmosphere from the soybean but there is a net CO₂ influx caused by the fossil-fuel inputs currently used to produce and process soybeans (Marland and Turhollow 1991).

We assumed that CO₂ uptake by the soybean plant is released back to the environment through decomposition of plant residue, left in the field after harvesting, or through the combustion of biodiesel made from soybeans. Thus, the net biomass-derived CO₂ balance for growing and burning soybean biodiesel is zero. CO₂ sequestered in the beans is carried through the LCA as CO₂ (biomass) versus CO₂ (fossil), which results from the combustion of petroleum resources, such as the methanol component of the biodiesel. Emissions and CO₂ releases from processing and producing farm inputs are accounted for separately (fossil CO₂) from the CO₂ sequestered and subsequently released from burning the biomass fraction of the biodiesel made from soybeans (biomass CO₂).

Process flows (energy requirements and environmental outflows) associated with the production of capital equipment used on soybean farms are not included in the LCI. This is consistent with the modeling of the petroleum fuel system in which capital equipment was excluded.

5.1.2 Soybean Agriculture Materials Consumption

Reliable data on farm inputs are required to estimate the LCI; current data must be used because U.S. agriculture is very dynamic. The most current source of farm input data for soybean production is from USDA's 1990 Farm Costs and Returns Survey (FCRS).

The FCRS is conducted annually by USDA's Economic Research Service (ERS) and USDA's National Agricultural Statistical Service (NASS). The commodity cost-of-production version of FCRS has questions about whole-farm expenses and detailed information about input use, field operations, and production costs of a particular crop.

A special soybean production questionnaire was included in the 1990 FCRS for 20 soybean-production states. The 1990 FCRS represents about 272,000 farms that planted soybeans on 44 million acres and produced 1.4 billion bushels, accounting for approximately 75% of the U.S. production of soybeans.

Data on inputs used to grow soybeans such as fertilizers, chemicals, liquid fuels, electricity, and natural gas are published by ERS (Ali and McBride). The yield data used in this study come from NASS. Ali and McBride report FCRS data on input use of soybean farms for the major soybean-producing states: Alabama, Arkansas, Georgia, Illinois, Indiana, Iowa, Kansas, Minnesota, Mississippi, Missouri, Nebraska, Ohio, South Carolina, and South Dakota. These 14 states account for 86% of soybean production. Soybeans produced in another 15 states account for most of the remaining soybean production in the United States.

Each of the 14 soybean-producing states considered in this study uses a certain amount of the materials and energy inputs (shown in Figure 42) to grow an amount of soybeans. Table 49 shows each input to the soybean agriculture system and associated yields for each of the 14 states considered in this study based on a per acre, per year consumption, and a weighted average.

5.1.2.1 Fertilizers and Agrochemicals

Soybeans remove essential minerals from the soil which must be replaced to maintain soil productivity. As a rule, soybeans remove about 0.9 lb (408 g) of phosphorus per bushel of beans harvested (Chapman and Carter 1976). Soybeans also use large amounts of potassium, removing about 1.2 lb (545 g) of potassium from the soil for each bushel of beans harvested (Chapman and Carter 1976). Nitrogen fertilizer is seldom required for successful soybean production because, like all members of the legume family, soybeans fix atmospheric nitrogen if the proper strain of *Rhizobium* bacteria is present in the soil or if the seed is properly inoculated (Chapman and Carter 1976). Thus, only small amounts of nitrogen fertilizer are used on U.S. soybeans.

The amount of fertilizer used per acre is given in the report by Ali and McBride for the 14 soybean-producing states considered in this study for the year 1990. The values are given in pounds of N, P₂O₅, and K₂O per acre for nitrogen, phosphorous, and potassium fertilizers, respectively. These values are then converted to kg per acre per year.

The small amount of nitrogen applied to soybeans is assumed to be in the form of ammonium nitrate (NH₄NO₃), phosphorous applied is assumed to be in the form of triple superphosphate (TSP), and potassium applied is assumed to be in the form of K₂O (Phosphate and Potash Institute 1996).

The production of these fertilizers (including energy requirements and emissions) is based on Ecobalance's LCA database DEAMTM as outlined in section 7.2.2 Fertilizers and Agrochemicals.

The actual amount of chemicals (e.g., pesticides and insecticides) applied to soybean acreage is not provided by Ali and McBride. However, they do report information on chemical expenditures as collected from the FCRS. These expenditures were converted to lb and then kg of agrochemicals used per acre for 1990, based on percentage of acreage treated and composite farm pesticide prices (weighted average cost of all chemicals). The production of agrochemicals (including energy requirements and emissions) is based on Ecobalance's LCA database DEAMTM as outlined in section 7.2.2 Fertilizers and Agrochemicals.

Table 49: Soybean Agriculture System Inputs

Item	Unit	AL	AR	GA	IL	IN	IA	KS	MN	MS	MO	NE	OH	SC	SD	14-State weighted average
Seed	lbs/acre	56	69	55	61	62	62	63	64	55	58	62	81	41	60	62.66
Fertilizer:																
Nitrogen	lbs/acre	8	13	13	5	8	12	41	10	19	6	6	5	3	5	9.89
Phosphate	lbs/acre	41	31	44	41	44	18	41	19	44	33	22	25	40	20	31.02
Potash	lbs/acre	54	44	85	86	47	60	7	31	70	50	5	56	84	7	52.80
Energy:																
Gasoline	Gal./acre	4.27	4.18	3.4	2.72	2.95	2.77	3.95	3.03	2.52	2.97	4.09	3.6	2.55	2.76	3.11
Diesel	Gal./acre	6.75	9.19	6.84	4.1	4.49	4.35	3.98	5.68	7.44	3.84	9.63	4.41	8.54	4.85	5.29
LP	Gal./acre	0.02	0.07	0.11	0.35	0.01	0	0	0	0.24	0.41	4.96	0.03	0.01	0.12	0.38
Electricity	kWh/acre	0	6.81	21.83	0	0.51	0	1.98	0.21	4.3	0	50.44	0.82	0.08	18.93	4.60
Natural Gas	C.F./acre	0	0.01	0	0	0	0	0.28	0	0.02	0	1.15	0	0	0	0.07
Custom operations	\$/acre	1.15	1.74	4.03	1.69	2.67	5.15	2.99	4.89	4.85	7.3	3.72	6.24	0.81	1.71	3.82
Chemicals	\$/acre	14.51	16.15	13.95	19.24	24.76	24.11	14	21.87	20.49	19.99	18.87	23.57	21.35	17.06	20.58
Soybean yield																
Avg. (89-91)	Bu/acre	20	26	22	39	39	40	25	38	22	29	33	36	21	27	34
Avg. (90-92)	Bu/acre	23	29	23	40	41	42	28	36	27	33	37	38	21	28	36
Avg. (92-94)	Bu/acre	28	31	26	44	45	42	34	32	29	36	42	41	21	30	38
Ag. Chemical Application:																
Herbicides	Percent	100	100	82	100	100	100	100	100	100	100	96	100	100	100	99
Insecticides	Percent	0	0	18	0	0	0	0	0	0	0	4	0	0	0	1
Composite Farm Pesticide Prices:																
Herbicides	\$/lb															5.04
Insecticides	\$/lb															12.33
Chemicals	lbs/acre	2.88	3.20	2.47	3.82	4.91	4.78	2.78	4.34	4.07	3.97	3.66	4.68	4.24	3.38	4.06
Custom operations (diesel fuel use)	Gal/acre	0.21	0.32	0.73	0.31	0.49	0.94	0.54	0.89	0.88	1.33	0.68	1.14	0.15	0.31	0.70
Lubricants (motor oil)	gal./acre	0.34	0.41	0.32	0.21	0.23	0.22	0.24	0.27	0.31	0.21	0.42	0.25	0.34	0.23	0.26

Table 50: Irrigation Water Used on Soybeans by State per Year (1994)

State	Liters/Hectare/year	Gallons/Acre/year	Inches/Acre/year
Arkansas	2.4 x 10 ⁶	260,720	9.6
Georgia	1.2 x 10 ⁶	130,360	4.8
Illinois	1.8 x 10 ⁶	195,540	7.2
Kansas	3.3 x 10 ⁶	358,490	13.2
Minnesota	1.2 x 10 ⁶	130,360	4.8
Mississippi	2.1 x 10 ⁶	228,130	8.4
Missouri	1.5 x 10 ⁶	162,950	6.0
Nebraska	1.8 x 10 ⁶	195,540	7.2
South Dakota	1.8 x 10 ⁶	195,540	7.2

5.1.2.2 Water Use

The U.S. Department of Commerce has published a Census of Agriculture on agriculture-related topics.⁴¹ The 1994 Farm and Ranch Irrigation Survey is part of this census and lists the estimated quantity of water applied to various types of crops. Information was obtained on irrigation water applied to soybean production by state. Of the 14 soybean-producing states considered in this project, only the states listed in Table 50.

5.1.3 Soybean Agriculture Energy and Equipment Use

5.1.3.1 Energy Use and Soybean Yield

Energy inputs for soybean production include gasoline, diesel fuel, liquefied petroleum gas (LPG), natural gas, and electricity. These energy sources are required for field equipment (e.g., tractors and combines), as well as such activities as pumping irrigation water to soybean fields. The source of farm energy requirements is the FCRS produced for soybeans and reported by Ali and McBride. This survey lists the amounts of the different energy sources used per acre for each soybean-producing state in 1990.

The gallons of diesel fuel and gasoline used per acre of soybeans for 1990 is reported by the survey. Also, when a farmer hires machinery and labor to perform a farming operation, the FCRS refers to these expenses as custom operations. The fuel portion of custom operations for soybeans is not provided by the FCRS. We assumed that the fuel share of custom operations accounts for 16.4%⁴² of total cost, which is converted to gallons of diesel oil per acre of soybean based on prices of diesel fuel paid by farmers. The gallons of fuel used are then converted to liters for use in the model.

The LCI modeling of the production of diesel fuel and gasoline is an output of this study. Therefore, a loop for diesel fuel and gasoline is created in the model. The model was run the first time with values for production of #2 diesel fuel and gasoline based on Ecobalance's database. Then the new results of the model were taken and reinserted into the model to replace the previously used values for production of the refinery products. The model was rerun with the new values to obtain the final result.

⁴¹ This responsibility has since moved to the National Agricultural statistical Service within USDA.

⁴² Percentage is based on communications with the authors of the Farm Costs and Returns Survey.

Electricity use is given by the 1990 survey in terms of kWh used per acre of soybeans. This can then be converted to MJ of electricity used per acre for 1990. Electricity production is based on Ecobalance's database DEAM™ and is regionalized based on the electricity grid in the soybean producing states considered in this study.

LPG use is given in terms of gallons used per acre for 1990. This gallon amount is converted to an energy value based on the heating value of the LPG (95.3 MJ/gal). The same is true for natural gas use, which was reported as thousands of cubic feet of natural gas per acre. This is converted to an energy value based on the heating value of the natural gas (1.05 MJ/ft³). The production of natural gas and LPG is based on Ecobalance's database.

The energy value of growing seed is assumed to be equal to 150% of the energy required to grow soybeans. Soybean seed uses more energy than regular soybeans because of additional storage and packaging cost. Also, it takes more energy to haul the seed from a local seed company to retailers and from retailers to soybean farmers. This is accounted for in the model by adjusting the yield of the soybeans per acre. The yield of soybeans shown in Table 51 in bushels is converted to a weight based on a conversion factor of 27.2 kg/bushel of soybeans (USDA, ERS "Weights, Measures, and Conversion Factors for Agricultural Commodities and Their Products"). The amount of soybean seed used per acre is known from the FCRS. This value is multiplied by 1.5 and subtracted from the soybean yield to give an adjusted yield value that accounts for seed production.

Table 51: Average Soybean Yield (Bu/acre/yr)

<i>State</i>	<i>Three Year Average (bushels per acre per year)</i>		
	<i>1989-1991</i>	<i>1990- 992</i>	<i>1992-1994</i>
Alabama	20	23	28
Arkansas	26	29	31
Georgia	22	23	26
Illinois	39	40	44
Indiana	39	41	45
Iowa	40	42	42
Kansas	25	28	34
Minnesota	38	36	32
Mississippi	22	27	29
Missouri	29	33	36
Nebraska	33	37	42
Ohio	36	38	41
South Carolina	21	21	21
South Dakota	27	28	30

An example of how this is done for Alabama is shown as follows:

- 1 Bushels per acre per year (from Table 51) is multiplied by 27.2 (conversion factor) to give 761.6 kg of soybeans produced per acre per year in Alabama.
- 2 Seed used in Alabama per acre per year is 56 lb or 25.4 kg (FCRS). Multiplied by 1.5 to account for the extra energy of packaging, transport, etc. gives 38.1 kg of seed used per acre per year.
- 3 Subtract seed used from the yield to get 723.5 kg/acre per year.

Average annual soybean yields for 1989-1991, 1990-1992, and 1992-1994 are shown in Table 51 for each of the 14 major soybean-producing states (crop production annual summary). The 1992-1994 3-year average yield is used for this study to account for variation caused by weather and to reflect yield rate based on current farming technology. The 1992-1994 average soybean yield per acre, compared to the 1989-1991 average yield increased for every state except Minnesota. Minnesota's average yield declined by 16%. The largest increase occurred in Alabama—40%.

The energy information on soybean inputs recorded for the 14 soybean-producing are weighted by the fraction of the total soybean output produced from each state. Table 52 shows the soybean production of the 14 states used in this study for the years 1993, 1994, and 1995 as well as the average for those 3 years and the fraction of the total coming from each state.

The soybean production and inputs for each state were multiplied by the fraction of the total soybean production produced by that specific state (the final column of Table 52). This yields an estimate for the average U.S. production of soybeans.

Table 52: Soybean Production by State

<i>State</i>	<i>Production (1,000 bushels)</i>				<i>Fraction of Total</i>
	<i>1993</i>	<i>1994</i>	<i>1995</i>	<i>3 Year Avg.</i>	
Alabama	7,080	9,145	5,400	7,208	0.0038
Arkansas	92,300	115,600	86,700	98,200	0.052
Georgia	8,160	15,500	8,370	10,677	0.0057
Illinois	387,000	429,065	373,450	396,505	0.21
Indiana	223,100	215,260	194,220	210,860	0.11
Iowa	257,300	442,885	398,180	366,122	0.20
Kansas	53,200	73,500	51,250	59,317	0.032
Minnesota	115,000	224,000	232,000	190,333	0.10
Mississippi	42,900	57,035	37,800	45,912	0.024
Missouri	118,800	173,280	130,500	140,860	0.075
Nebraska	90,000	134,420	99,450	107,957	0.058
Ohio	156,180	173,565	153,140	160,962	0.086
South Carolina	7,800	15,660	12,720	12,060	0.0064
South Dakota	38,500	91,200	75,000	68,233	0.036
Total:				1,875,205	1.000

5.1.3.2 Energy Emissions

The emissions associated with farm equipment use are derived from data reported in the FCRS and in the Ali and McBride report describing soybean production. The survey reports gallons of diesel oil and gasoline used. We assumed that all the diesel oil is used in a diesel tractor, and that half the gasoline is used in a gasoline tractor and half is used in a truck. The emissions from the truck are based on Ecobalance's database DEAMTM. The emissions from the two types of tractors are shown in Table 53 and Table 54⁴³.

We assume natural gas is combusted in an internal combustion engine and LPG is assumed to be combusted in a commercial boiler. The emission factors for these combustion sources are shown in Appendix A.

Table 53: Emission Factors for Diesel Fuel Combustion in a Farming Tractor

Tractor Type	Emission Factors (g/MJ diesel fuel burned)							
	Hydrocarbons	CO	NO _x	PM10	SO ₂	CH ₄	N ₂ O	CO ₂
Diesel	0.085	0.32	0.89	0.041	0.12	0.0042	0.0019	75.5

Table 54: Emission Factors for Gasoline Combustion in a Farming Tractor

Tractor Type	Emission Factors (g/MJ gasoline burned)							
	Hydrocarbons	CO	NO _x	PM10	SO ₂	CH ₄	N ₂ O	CO ₂
Gasoline	0.20	1.14	0.63	0.0074	0.0046	0.032	0.0019	67.7

5.1.4 Soybean Agriculture Biological Interactions/Field Emissions

Fertilizers and pesticides applied to agricultural land are distributed between the plants in the field, soil, water, and air. Some of the chemicals applied to improve soybean productivity are absorbed by the soybean plant and soybean through the root system. Chemicals that go into the soybean move to the next phase of the LCA and are not a concern here. Chemicals absorbed by the plant or applied directly to the foliage (e.g., herbicides) eventually reach the soil during rainfall or when the soybeans are harvested. Most soybean crops are harvested with grain combines that separate the bean from the rest of the plant, leaving the residue on the field. In the Fall or early Spring, the crop residue is plowed into the soil, then disked and harrowed to prepare a firm seedbed for planting. Pesticides left in the field dissipate from the soil or enter the air through volatilization. Pesticides can also be carried away from the field by soil erosion.

Although farmers generally use soil tests to avoid over-fertilization and to determine precise fertilizer application rates that ensure good yields, not all the fertilizer is used by the plants. Unused fertilizer will degrade in the soil and some will completely dissipate. Some attaches to soil particles and moves off the field through soil erosion. Also, some of the applied fertilizer transforms into gases such as N₂O and NO_x and enters the atmosphere.

⁴³ Emission factors for fuel combustion are based on a project done by the Argonne National Laboratory (Argonne 1996). SO_x releases are based on burning high-sulfur diesel fuel, which is an acceptable fuel quality for farm equipment (off road vehicles). Only on road vehicles are required to use low-sulfur diesel fuel.

5.1.4.1 Soil Erosion^{3/4}National Resource Inventory

Soil erosion not only moves large amounts of soil away from the field, but it also is the main driver for removing unused farm chemicals and natural nutrients. Soil erosion data are available from USDA's National Resources Inventory (NRI). The NRI is an inventory of land use and soil erosion on prime farmland, wetlands, and other nonfederal rural land in the United States. The NRI erosion trends are reported by state and land use, e.g., cultivated cropland, non-cultivated cropland, pasture land, and range land. Inventories are conducted every 5 years by the National Resources Conservation Service (NRCS—formerly the Soil Conservation Service).

Data for the most recent survey, 1992, were collected for more than 800,000 locations. NRI data are statistically reliable for national, regional, state, and sub-state analysis (NRCS 1995).

In order to obtain erosion estimates for our 14 soybean states, the 1992 NRI data set was downloaded into an statistical analysis software file. Erosion estimates were averaged for land where soybeans were produced during the 1992 growing season. Missouri has the highest soil loss of 8.1 tons per acre of soybeans and South Dakota has the lowest, 2.8 tons per acre (Table 55). Alabama had the highest soil erosion overall, but Missouri had the highest soil erosion specifically associated with soybean production.

Sheet erosion occurs when there is a little water at the soil surface and it runs over the soil as a thin sheet. Rill erosion is due to the energy of water that has concentrated and is moving downslope. As water concentrates, it forms small channels called rills. Water collected into small rills coalesces to form large channels and produce gully erosion (Foth 1984).

In addition to erosion caused by water, Table 56 shows wind erosion on soybean cropland. Only seven of the 14 states studied reported wind erosion, which varied from 4.2 tons per acre in Minnesota to 0.20 tons per acre in Ohio.

The Universal Soil Loss Equation (USLE) is used to predict water erosion on agricultural land. It was designed to predict the long-term erosion rates on farmland so that management systems could be devised that result in acceptable levels of erosion. It is a complex equation that uses information on the quantity and intensity of rainfall, soil erodibility, slope length, slope gradient, cropping management practices, and erosion control practices.

The cropping management factor looks at vegetative cover, types of tillage (moldboard plow, minimum till, or no till), and crop rotation. Detailed tables are used to obtain information from the farmer to determine how management practices affect erosion. Information is collected on past years because crop rotation sequences, tilling practices, and other factors in previous years have a direct effect on current erosion rates. Thus, even though this project focuses on a single growing season for soybeans, the soil loss estimates for a given year depend on factors that occur in previous years.

Erosion control factors include contour tillage, strip cropping on the contour, and terrace systems. Since the 1920s federal legislation and government programs, such as USDA's Conservation Reserve Program (CRP) have provided incentives for farmers to use conservation practices. Even though soil loss is still considered a major problem, it has been declining in recent years. Soil loss from erosion on cropland dropped from a total of 3.1 billion tons on 421 million acres in 1982 to 2.1 tons on 382 million acres in 1992 (NRCS 1995).

**Table 55: Estimated Annual Average Sheet and Rill Erosion on
Total Cropland and Soybean Cropland—1992**

State	Total Cropland ⁴⁴ (tons/acre)	Std Dev.	Soybeans (tons/acre)	Std Dev.
Alabama	6.5	6.53	6.6	5.05
Arkansas	3.4	2.52	3.7	2.65
Georgia	5.1	6.10	6.9	6.58
Illinois	4.8	6.22	4.4	6.06
Indiana	3.4	4.83	3.4	4.62
Iowa	5.4	7.97	5.2	7.49
Kansas	2.6	4.55	5.4	7.99
Minnesota	2.8	4.37	3.2	4.61
Missouri	6.0	9.64	8.1	11.94
Mississippi	5.4	7.22	4.8	5.60
Nebraska	3.5	5.70	6.0	7.53
Ohio	3.0	4.48	3.2	4.18
South Carolina	3.4	4.44	3.8	4.75
South Dakota	2.0	2.94	2.8	3.98

5.1.4.2 Other Nutrients and Fertilizers Carried off the Field by Erosion

As pointed out earlier, soil is not the only item carried off a field by erosion. Fertilizers, pesticides, and soil nutrients are also transported. A large part of the soil erosion reported in Table 55 and Table 56 include natural nutrients such as nitrogen, phosphorus, and potassium. The Earth's crust contains about 0.1% phosphorus and 2.6% potassium (Foth 1984).

The atmosphere is made up of 79% nitrogen, which plants bring into the soil through nitrogen fixation. Soybeans fix as little as 15 kg of nitrogen/ha (13 lb/acre) and as much as 310 kg of nitrogen/ha (275 lb/acre) (NRC). Thus, the amounts of applied fertilizer and agrochemicals are relatively small compared to nutrients already in the soil. For example, on average soybeans receive only about 10 lb of nitrogen per acre and 4 lb of agrochemicals per acre.

⁴⁴ Excludes CRP land

Table 56: Estimated Annual Average Wind Erosion on Total Cropland and Soybean Cropland—1992

State	Total cropland* (tons/acre)	Std Dev.	Soybeans (tons/acre)	Std Dev.
Alabama	0	NA	0	NA
Arkansas	0	NA	0	NA
Georgia	0	NA	0	NA
Illinois	0	NA	0	NA
Indiana	0.35	1.43	0.26	1.22
Iowa	1.3	2.23	1.8	2.59
Kansas	1.9	4.55	0.30	1.80
Minnesota	4.4	5.37	4.2	4.23
Missouri	0	NA	0	NA
Mississippi	0	NA	0	0
Nebraska	1.4	3.18	0.90	2.40
Ohio	0.10	0.509	0.20	0.689
South Carolina	0	NA	0	0
South Dakota	2.1	3.97	1.4	2.67

* Excludes CRP land.

The next question is: How much of the soil, fertilizer, and agrochemicals carried away from the field go to natural or constructed waterways? Ribaudo (Ribaudo 1989) shows how soil erosion and fertilizer affect the amounts of sediment and nutrients discharged into waterways. His estimates are based on levels of total suspended sediment (TSS), total Kjeldahl nitrogen (TKN), and total phosphorus (TP) that are discharged into waterways each year as estimated by Resources for the Future (RFF, Gianessi). RFF estimated the discharge of materials associated with soil particles by estimating sediment delivery ratios and attached pollutant coefficients, then applying them to soil erosion data (excluding wind erosion). Sediment delivery ratios are a function of stream density and soil type. Attached pollutant coefficients are the ratios of the weight of the nutrients attached to soil particles to the weight of soil particles (Ribaudo 1989).

RFF used a nutrient simulation model to estimate the amount of materials dissolved in runoff from cropland. Information on discharges came from EPA discharge permits. Estimates of annual discharge of TSS, TKN, and TP were made for 99 Aggregated Subareas (ASAs). ASAs are hydrologic units, usually the basins of major rivers, for which there are data on the discharge of TSS, TKN, and TP. Ribaudo provided sediment delivery ratios and attached pollutant coefficients for TKN and TP for regions in which our 14 states are located. Multiplying sediment delivery ratios from each state times the estimated soil erosion from each state gives TSS. The sediment delivery ratio times the nitrogen coefficient, times the erosion estimate, gives the amount of TKN carried away with the sediment. And the sediment delivery ratio times the phosphorus coefficient, times the state erosion estimate, gives the amount of TP carried away with the sediment for each state.

Table 57 shows the expected amounts of soil sediment, nitrogen and phosphorus that move from the field and into the nearby water system. The nitrogen and phosphorus runoff includes natural nutrients and applied fertilizer. For example, the annual soil that is dislodged by water and carried to the edge of the field in Alabama is 6.6 tons per acre. Of this 6.6 tons of soil, 2.55 tons are sediment, 0.043 tons are nitrogen, and 0.005 tons are phosphorus that move from the edge of the field and into the local waterway. These estimates represent land in our 14 states where soybeans are grown. As discussed earlier, erosion estimates are for a single growing season but data from previous years related to crop rotations and other management practices are included in the calculations.

Table 57: Annual Erosion and Discharge of TSS, TKN, and TP on Soybean Acreage

<i>State</i>	<i>Erosion*</i> (tons/ac/yr)	<i>Sediment</i> <i>Delivery Ratio</i>	<i>TSS</i> (tons/ac/yr)	<i>Nitrogen</i> <i>Coefficient</i>	<i>Phosphorus</i> <i>Coefficient</i>	<i>TKN</i> (tons/ac/yr)	<i>TP</i> (tons/ac/yr)
Alabama	6.6	0.387	2.55	0.017	0.002	0.043	0.0051
Arkansas	3.7	0.548	2.03	0.011	0.002	0.022	0.0041
Georgia	6.9	0.387	2.67	0.017	0.002	0.045	0.0053
Illinois	4.4	0.512	2.25	0.038	0.006	0.086	0.0135
Indiana	3.4	0.512	1.74	0.038	0.006	0.066	0.0104
Iowa	5.2	0.512	2.66	0.038	0.006	0.101	0.0160
Kansas	5.4	0.473	2.55	0.021	0.004	0.054	0.0102
Minnesota	3.2	0.369	1.18	0.041	0.004	0.048	0.0047
Mississippi	4.8	0.548	2.63	0.011	0.002	0.029	0.0053
Missouri	8.1	0.512	4.15	0.038	0.006	0.158	0.0249
Nebraska	6.0	0.473	2.84	0.040	0.004	0.114	0.0114
Ohio	3.2	0.512	1.64	0.038	0.006	0.062	0.0098
South Carolina	3.8	0.387	1.47	0.017	0.002	0.025	0.0029
South Dakota	2.8	0.473	1.32	0.021	0.004	0.028	0.0053

* Includes sheet and rill erosion.

5.1.4.3 Agrochemicals in Waterways

Pesticides include herbicides, insecticides, and fungicides. Most soybean acreage received pesticides in 1992, but nearly all pesticides used on soybeans (99%) were herbicides (Lin et al. 1995). Pesticides contribute to increased productivity, but their use has received increased scrutiny because of human health and environmental risks. Federally funded programs began in the early 1970s developed an “Integrated Pest Management” (IPM) approach to controlling pests (Vandeman et al. 1994). IPM encourages natural control of pest populations by anticipating pest problems and preventing pests from reaching economically damaging levels.

Control techniques include enhancing natural enemies, planting pest-resistant crops, adapting cultural management, and using pesticides judiciously (Agricultural Research Service 1993). The Clinton Administration has made IPM an important part of its legislative reform proposals. In September 1993, the Administration committed to research and education efforts necessary to achieve the adoption of IPM on 75% of the nation’s crop acreage by the year 2000.

Recent information collected by USDA on the adoption of IPM techniques shows significant progress in the adoption of IPM on U.S. farms (Vandeman et al. 1994). For example, results from the USDA survey reflect the greater availability of post-emergence herbicides for use in soybean production (Vandeman et al 1994). Post-emergence herbicides are better than pre-emergence herbicides (applied before planting) because they have little or no soil residual activity and are applied only when needed. There is a trend toward more use of post-emergence herbicides, which is expected to accelerate in the future for two reasons (Kapusta 1992). First, the cost of some post-emergence herbicides has been declining; Second, conservation tillage has increased, which limits the option of incorporating pre-emergence herbicides into the soil.

Another example of IPM on soybeans is using crop rotations and leaving crop residues. Crop residues can decrease pesticide runoff, and crop rotation can effectively interrupt the development of the disease and weed life cycle. See Lin et al.1995 and Vandeman et al.1994 for a further description of IPM adoption.

Generally, herbicide runoff is much smaller than fertilizer runoff because application rates are much smaller—the application rate for herbicides per planted acre of soybeans was 4.06 lb in 1992. This compares to about 31 lb/acre for phosphate and 53 lb/acre for potash as shown in Table 49. Herbicides leaving a treated area in runoff constitute only a small percentage of that applied because most of the applied herbicide is dissipated by other processes (Leonard 1988). Once an herbicide reaches either the plant or soil surface, it is degraded or transformed by chemical, biological, and photochemical processes and subjected to volatilization losses. Runoff is worse when there is heavy rainfall shortly after application but as discussed previously, the adoption of IPM has placed increased emphasis on the correct timing of pesticide application.

Wauchope (Wauchope 1978) conducted an extensive review of available data and proposed a rule-of-thumb pesticide classification with estimates of average or reasonably expected edge-of-field runoff losses. Estimated seasonal losses were 1% of the amount applied for foliar-applied organochlorine insecticides, 2% to 5 % for wettable powder, depending on slope and hydrologic response, and 0.3% or less for the remaining pesticides. Runoff losses in the range of 1% to 2% are not uncommon for a wide range of pesticides. He defined “catastrophic” events as those in which runoff losses exceed 2% of application. These are usually with the first storms after recent application.

There is a great deal of variation in herbicide runoff depending on crop stage; type of herbicide; whether it is a powder, granular, or spray application method; soil texture, and weather conditions. Calculating an average runoff for our 14 states would be an arduous task. For example, USDA reported 38 types of herbicides used on soybeans in 1995, with each state using various combinations and quantities of these herbicides. In addition, when variability in weather and other factors among the 14 states are considered, it is not clear what an average runoff level would represent.

Pesticides can also reach waterways by leaching into groundwater basins. The tendency of a pesticide to leach depends on solubility, sorption, and persistence. Sorption is commonly evaluated by use of a sorption coefficient based on the organic carbon content of soils. Persistence is commonly evaluated in terms of half-life, which is the time that it takes for 50% of a chemical to be degraded or transformed. Pesticides with low sorption coefficients, long half-lives, and high water solubility are likely to leach and contaminate groundwater (NRC).

The travel time of a pesticide to the water table may only be a few days to a week; if the soil is permeable, rainfall exceeds water-holding capacity of the soil and if the depth to the water table is shallow. In contrast, the travel time may be decades in arid regions where the water table is far below the land surface (NRC). The further the pesticide must travel to reach the water table, the more it is subject to degradation and immobilization mechanisms. Thus, in cases where it takes years for pesticides to leach into the water table, only a minuscule amount of contaminant may reach the water supply.

This is not to say that small amounts of pesticides in the water system are not hazardous, but quantifying these contaminants is extremely difficult. Transformations and transport of pesticides are strongly influenced by site-specific conditions and management practices (NRC). In addition, pesticides include a broad class of agrochemicals with widely ranging properties that defy generalizations. Computer simulation models are being developed to evaluate more fully the fate and transport of pesticides. But at this time, there are no appropriate estimates available to calculate the amount of pesticides that may leach into the groundwater in the production of soybeans.

For this study, pesticides and herbicides are grouped into one agrochemicals category that represents all the chemicals applied to the soybeans during planting and growing. Of these agrochemicals, a runoff coefficient of 3% of the weight of the chemicals applied is used to estimate the amount of agrochemicals lost to runoff (which is the average of the reported range 1%-5%).

5.1.4.4 Agrochemicals in the Atmosphere

Spray application is the major source of atmospheric contamination by pesticides because of drift and vaporization (Lewis and Lee 1976). Studies have found that large amounts of aerially applied pesticides miss their agricultural targets. Drift loss depends on factors such as wind, size, and height at which the material is released. However, most soybean acreage receives herbicides by ground broadcast (90%) and IPM application timing recommendations help to minimize drift. Only about 2% is applied by aerial broadcast and about 8% by band treatment (ERS, AREI 1994). Banded treatment is applying pesticides over, or next to, each row of plants in a field.

Majewski and Capel (Majewski and Capel 1995) showed that drift for ground-rig applications ranged from less than 0.5% to 8% of the nominal application and was dependent on the nozzle type, hydraulic pressure, and wind speed. The drift from aircraft applications ranged from 1% to 31%.

In addition to application drift, pesticide residues can be transported into the atmosphere attached to dust particles disturbed during tilling operations. This represents a secondary form of off-target pesticide drift that takes place over a much longer period. No-till or minimum till can help minimize soil disturbances.

Another major route of entry of pesticides into the atmosphere is through volatilization from treated agricultural soils and plant foliage. Volatilization occurs when herbicides reach the plant or soil surface and are degraded or transformed by chemical, biological, and photochemical processes and enter the atmosphere.

Volatilization is a major cause of disappearance of herbicides from target areas, particularly where they are surface applied, and the rate of this loss can exceed that of chemical degradation (Taylor and Glotfelty 1988). The rate of volatilization will depend the moisture content of the soil (wet is worse than dry), temperature, the relative humidity, wind velocity, and soil type (Lewis and Lee 1976)⁴⁵. Volatilization is continuous, even though the rate is variable. Peak periods of volatilization occur during the application phase, following a rain event or during irrigation. When spray application is used, loss from volatilization ranges from 3% to 25% for most pesticides, but for some pesticides it may be as great as 20% to 90%, depending on weather conditions. In contrast, pesticide losses from soil-incorporated application methods are usually much lower.

The total amounts of chemicals applied to soybean agriculture are shown in Table 49 for each of the 14 states considered in this study and for the 14-state weighted average. It is also seen that 99% of the applied chemicals are herbicides. The exact types of chemicals applied are found in the USDA study "Pesticide and Fertilizer Use Trends in U.S. Agriculture." Table 58 shows the chemicals used.

⁴⁵ Volatilization is often too variable to make generalizations. The range of loss is listed as somewhere between 0 and 90 percent depending on time, moisture, soil, type of compound, application method, etc. (Grover). There are equations that can be used to estimate volatilization rates, but they require very site-specific information.

Table 58: Amounts and Types of Herbicides Applied to Soybean Agriculture

<i>Herbicide:</i>	<i>Million Pounds Active Ingredient/Acre</i>				<i>Percent of Total</i>
	<i>1990</i>	<i>1991</i>	<i>1992</i>	<i>3 yr Avg.</i>	
Actifluorfen	1.1	0.9	1.1	1.0	1.6%
Alachlor	14.7	12.8	10.2	12.6	20%
Bentazon	6.1	4.2	4.8	5.0	8.0%
Chloramben	0.7	0.2		0.3	0.47%
Chlorimuron	0.3	0.2	0.2	0.2	0.37%
Clomazon	2.7	1.9	1.4	2.0	3.2%
Ethalfluralin	2.4	1.4	0.9	1.6	2.5%
Glyphosate	2.7	2.4	2.4	2.5	4.0%
Imazaquin	1.0	0.8	0.9	0.9	1.4%
Imazethapyr	0.4	0.7	0.9	0.7	1.1%
Linuron	2.0	1.0	0.5	1.2	1.8%
Metolachlor	9.9	7.6	5.9	7.8	12%
Metribuzin	3.6	2.7	2.2	2.8	4.5%
Pendimethalin	6.8	7.9	9.7	8.1	13%
Trifuralin	17.6	16.3	15.6	16.5	26%
Total:	72	61	56.7	63.2	100%

Of these herbicides, the Pesticide and Fertilizer Use Trends report states that Trifuralin is applied through soil incorporation, the remaining herbicides are assumed to be applied through surface application.

The EPA AP-42 document provides emission factors for the volatilization of agrochemicals based on the method of application (soil incorporation versus surface application) and on the vapor pressure of the chemicals. AP-42 also provides a factor for estimating the VOC content of the inert portion of the chemicals applied. The Pesticide and Fertilizer Use Trends report supplies an estimate of the average amount of herbicide active ingredient applied per treated acre of soybeans. The 3-year average (1990-1992) is 1.23 lb/treated acre. This value is adjusted based on the amount of treated acres (96 %) to give an average per acre of soybeans (1.29 lb/acre soybeans). The total amount of chemicals applied is known to be 4.06 pounds per acre of soybeans (shown in Table 49). Therefore, the percentage of inert ingredients in the chemicals applied is 68%.

The amount of herbicides volatilized is calculated based on the vapor pressures of the active ingredients and the application method, as well as the VOC content of the inert ingredients (assumed to be 32% based on an average value from AP-42). Trifuralin, which represents 26% of the total chemicals applied, is assumed to be soil incorporated and have a vapor pressure of 1.1 E-04 mm Hg at 20°C. The remaining chemicals are assumed to be surface applied and a weighed average vapor pressure is used as shown in Table 59.

Table 59: Weighted Average Vapor Pressure of Surface-Applied Agrochemicals

<i>Herbicide</i>	<i>3 yr Avg.</i>	<i>Percent of Total</i>	<i>Vapor Pressure (mm Hg)</i>	<i>Weighted Average Vapor Pressure (mm Hg)</i>
Actifluorfen	1.0	2.2%	4.9 E-09	1.1 E-10
Alachlor	12.6	26.9%	1.4 E-05	3.8 E-06
Bentazon	5.0	10.8%	3.8 E-09	4.1 E-10
Chloramben	0.3	0.6%	7.0 E-03	4.5 E-05
Chlorimuron	0.2	0.5%	3.7 E-12	1.8 E-14
Clomazon	2.0	4.3%	1.4 E-04	6.0 E-06
Ethalfuralin	1.6	3.4%	8.8 E-05	3.0 E-06
Glyphosate	2.5	5.3%	3.8 E-08	2.0 E-09
Imazaquin	0.9	1.9%	4.9 E-08	9.4 E-10
Imazethapyr	0.7	1.4%	4.9 E-08	7.0 E-10
Linuron	1.2	2.5%	1.7 E-05	4.2 E-07
Metolachlor	7.8	16.7%	3.1 E-05	5.2 E-06
Metribuzin	2.8	6.1%	5.0 E-06	3.0 E-07
Pendimethalin	8.1	17.4%	9.4 E-06	1.6 E-06
Total	46.7	100.0%		6.5 E-05

The calculation of the emissions from chemical applications for soybean production is shown as follows:

- Of the 4.06 lb of chemicals applied per acre of soybeans per year, 68% is inert material. This comes to 2.76 lb. From AP-42, the average VOC content of the inert ingredients of agrochemicals is 32%. This leads to **0.88 lb of VOC** per acre of soybeans per year due to the inert ingredients of the chemicals applied.
- Of the active ingredients of chemicals applied per acre of soybeans per year (4.06 - 2.76 = 1.3 lb), 26% of it is applied through soil incorporation or 0.34 lb. Table 60 from AP-42 shows the emission factors for soil-incorporated chemicals based on their vapor pressure.
-

Table 60: VOC Emission Factors for Soil-Incorporated Agrochemicals

<i>Vapor Pressure Range (mm HG at 20° to 25°C)</i>	<i>Emission Factor (% of applied chemical)</i>
< 1 x 10 ⁻⁶	0.27 %
1 x 10 ⁻⁴ to 1 x 10 ⁻⁶	2.1 %
> 1 x 10 ⁻⁴	5.2 %

- The soil-incorporated chemical in this case has a vapor pressure of 1.1×10^{-4} mm Hg at 20°C. Therefore, the emission factor of 5.2% is applied to the amount of active ingredient applied: $0.34 \times 5.2\% = \mathbf{0.017 \text{ lb of VOC}}$ per acre of soybeans per year.
- The remaining active ingredients of chemicals applied per acre of soybeans per year ($1.3 - 0.34 = 0.96$ lb) are surface applied. Table 61 from AP-42 shows the emission factors for surface-applied chemicals based on their vapor pressure.

Table 61: VOC Emission Factors for Surface-Applied Agrochemicals

<i>Vapor Pressure Range (mm HG at 20° to 25°C)</i>	<i>Emission Factor(% of applied chemical)</i>
1×10^{-4} to 1×10^{-6}	35 %
$> 1 \times 10^{-4}$	58 %

- The surface-applied chemical in this case has a vapor pressure of 6.5×10^{-5} mm Hg at 20°C. Therefore, the emission factor of 35% is applied to the amount of active ingredient applied: $0.96 \times 35\% = \mathbf{0.34 \text{ lb of VOC}}$ per acre of soybeans per year.

Based on these calculations, for every 4.06 lb of chemicals applied 1.24 lb are lost to the atmosphere through volatilization ($0.88 + 0.017 + 0.34$). This represents 31% of the total amount of chemicals applied.

Therefore, for this model it is assumed that 31% (by weight) of the agrochemicals applied to soybean agriculture are volatilized. This results in a release of unspecified HC air emissions from soybean agriculture.

5.1.4.5 NO_x and N₂O Emissions from Soil

It is possible for the nitrogen applied to soil as fertilizer to be released into the atmosphere as N₂O, and NO_x (NO + NO₂ = NO_x). The amount depends on the quantity and type of fertilizer, soil conditions and water content, crop type, agricultural practices, and weather conditions, particularly rainfall. A review of field experiments on *corn* found that about 0%-1.8% (average 1.3%) of the nitrogen in the fertilizer had evolved to the atmosphere as nitrogen in N₂O during the study period (Eichner 1990). Mosier (Mosier 1986) found 1.5% for corn but only 0.4% for barley.

It is expected that fertilizers continue to produce N₂O after the study period and some evolves off the site. Researchers have doubled the N₂O estimate to account for these other effects. Thus, about 2.6% of the nitrogen in the fertilizer applied to cornfields ends up as nitrogen in N₂O in the air.

Although soybeans don't generally need nitrogen fertilizer (10 lb of nitrogen/acre compared to 123 lb/acre for corn), they contribute to nitrogen emissions indirectly. Soybean production systems produce soybeans and nitrogen fertilizer for the next growing season through nitrogen fixation. That nitrogen fixation leads to nitrogen emissions in the following year when decomposition occurs. Brenner et al. sampled sites cropped with soybeans in six different soil types. Emissions ranged from 0.34 to 1.97 kg N₂O-N ha⁻¹yr⁻¹ with an average of 1.2 kg N₂O-N ha⁻¹yr⁻¹. Comparisons to non-legumes crops or to uncultivated soil were not included in the study; thus, these values include natural emissions, emissions associated with cultivation, and emissions from N fixed by the legume crop. However, on a relative basis, the N₂O emissions from soybeans appear to be much lower than the N₂O from growing corn. Estimates of total N₂O emissions on two corn fields were 3.60 kg N₂O-N ha⁻¹ and 5.20 kg N₂O-N ha⁻¹ (Cates and Kenney 1987).

It is generally agreed that the preponderance of NO_x emitted by soil is NO, with direct soil emission of NO₂ accounting for less than 10% of the total (Williams et al. 1992). Williams et al. (Williams et al. 1992) review current literature on soil emissions, including a field study that estimates the emissions of NO in a soybean/corn rotation (Anderson and Levine). During the soybean cycle, field measurements of NO ranged from 0.7 ngN/m²/s to 9.4 ngN/m²/s with a mean of 4 ngN/m²/s. During the corn cycle, with nitrogen fertilizer added, emissions of NO ranged from 6 ngN/m²/s to 67 ngN/m²/s with a mean of 25 ngN/m²/s.

Emissions of N₂O and NO_x from soil to the atmosphere have thus far been calculated from a very small database obtained under a very limited variety of conditions. A summary of study results indicates considerable spatial and temporal variability in emission estimates. Given the large degree of variability in the data, extrapolation is highly uncertain (Williams, et al. 1992). In addition, field tests on soybeans did not include a sample of emissions from an uncultivated soil control site. Consequently, the soybean-derived emissions cannot be distinguished from natural sources of N₂O and NO_x. Available studies agree that soil emissions are associated with crop production, including soybeans, and that adding fertilizer to these crops can increase these emissions appreciably (Eichner 1990). However, the lack of consistent data and high degree of variability in soil emission measurements prevents us from deriving a meaningful expected soil emission estimate for soybeans.

Therefore, although the range of values for possible N₂O and NO_x emissions is available, the uncertainty involved is too great to determine a meaningful estimate. For this model the field emissions for N₂O and NO_x will not be reported to prevent any misinterpretation of the overall results.

5.1.5 Soybean Agriculture LCI Results

Figure 43 presents a schematic of the TEAM™ model for soybean agriculture. Table 62 shows the corresponding LCI results for soybean agriculture for the production of 1 kg soybeans.

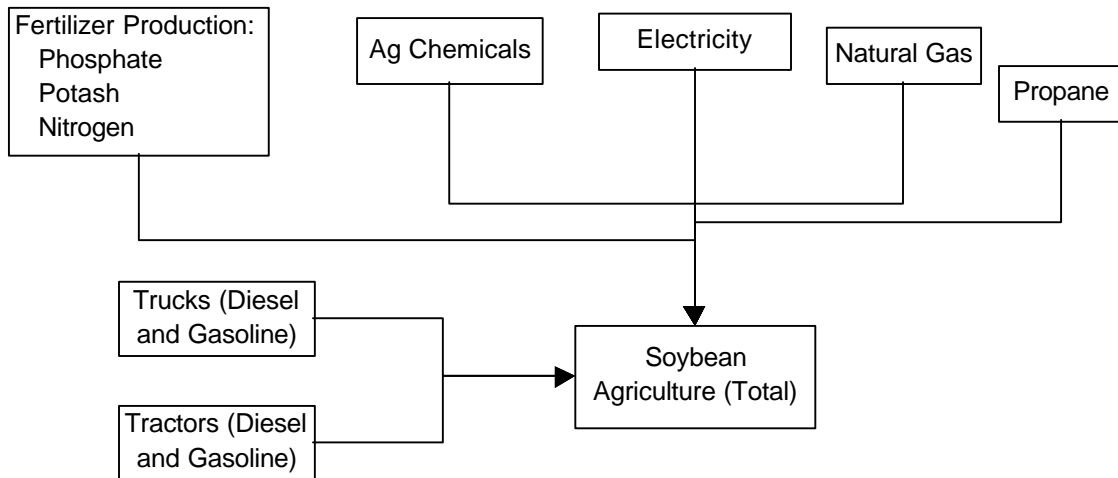

Figure 43: Schematic of TEAM™ Model Inputs to Soybean Agriculture

Table 62: LCI Results for Soybean Agriculture (for 1 kg of soybeans)

	Units	Soybean Agriculture (total)	Diesel Tractor	Gasoline Tractor	Gasoline Truck	Natural Gas Use	Propane Use	Electricity Use	Nitrogen Fertilizer Production	Phosphate Fertilizer Production	Potash Fertilizer Production	Agrochemicals Production	Soybean Agriculture
Raw Materials													
Coal (in ground)	kg	0.008471	0.00076	0.0002	0.0002	3.14E-12	1.51E-	0.001978	0.000640	0.00218	0.001812	0.000699	0
Oil (in ground)	kg	0.043558	0.02453	0.0064	0.0064	4.09E-12	1.97E-	4.61E-05	2.20E-05	0.00057	6.30E-05	0.005527	0
Natural Gas (in ground)	kg	0.016584	0.00210	0.00055	0.00055	1.78E-06	0.00085	9.00E-05	0.005744	0.00179	0.000864	0.004028	0
Uranium (U, ore)	kg	4.65E-07	1.82E-	4.76E-09	4.76E-09	7.52E-17	3.62E-	3.25E-08	1.53E-08	5.12E-08	4.34E-08	2.95E-07	0
Phosphate Rock (in ground)	kg	0.059960	0	0	0	0	0	0	0	0.05996	0	0	0
Potash (K ₂ O, in ground)	kg	0.028182	0	0	0	0	0	0	0	0	0.02818	0	0
Perlite (SiO ₂ , ore)	kg	8.49E-06	5.58E-	1.45E-06	1.45E-06	0	0	0	0	0	0	0	0
Limestone (CaCO ₃ , in ground)	kg	0.001096	0.00014	3.79E-05	3.79E-05	5.95E-13	2.86E-	0	0.00012	0.00041	0.00035	0	0
Sodium Chloride (NaCl)	kg	0	0	0	0	0	0	0	0	0	0	0	0
Water Used (total)	liter	550.35	0.00341	0.00089	0.00089	5.05E-13	2.43E-	4.04E-05	0.0069	0.00615	5.57E-05	0.005210	550.329
Air Emissions													
Carbon Dioxide (CO ₂ , fossil)	g	182.87	84.6843	20.7032	21.328	0.00497	2.61254	4.40514	17.9255	11.9934	7.5756	11.6376	0
Carbon Dioxide (CO ₂ , biomass)	g	-1832.98	0	0	0	0	0	0	0	0	0	0	-1832.98
Methane (CH ₄)	g	0.18082	0.03045	0.01529	0.00810	3.65E-05	0.00417	0.00064	0.032338	0.03139	0.01677	0.041635	0
Nitrous Oxide (N ₂ O)	g	0.00835	0.00273	0.00073	0.00243	1.77E-07	8.49E-	0.00035	8.04E-05	0.00041	0.00011	0.001414	0
Carbon Monoxide (CO)	g	0.87327	0.32102	0.29183	0.18872	3.24E-05	0.00071	0.00073	0.057599	0.00590	0.00191	0.004821	0
Hydrocarbons (except methane)	g	0.34422	0.08699	0.05370	0.02437	4.76E-05	7.29E-	0.03987	3.01E-05	0.02505	6.80E-05	0.114106	0
Hydrocarbons (unspecified)	g	0.73962	0.03234	0.00843	0.00843	3.57E-11	9.49E-	0	5.24E-05	0.00084	0.000152	0	0.68928
Benzene	g	8.38E-06	5.50E-	1.44E-06	1.44E-06	0	0	0	0	0	0	0	0
Formaldehyde	g	0.000113	7.37E-	1.92E-05	1.92E-05	4.99E-21	2.40E-	0	1.03E-13	1.20E-06	2.11E-09	0	0
Particulates (PM10)	g	0.087500	0.03997	0.00195	0.02822	9.87E-07	0.00012	0	0.01115	0.00609	0	0	0
Particulates (unspecified)	g	0.098765	0.01745	0.00455	0.00455	3.19E-09	1.53E-	0.00366	0.00919	0.03181	0.02555	0.002003	0
Sulfur Oxides (SO _x as SO ₂)	g	0.599564	0.21008	0.02676	0.03140	4.03E-05	0.0195	0.03826	0.14005	0.04713	0.04710	0.039243	0
Nitrogen Oxides (NO _x as NO ₂)	g	1.283880	0.89468	0.17282	0.03759	9.03E-05	0.00416	0.01924	0.06889	0.03897	0.02011	0.027327	0
Hydrogen Chloride (HCl)	g	0.001799	0.00041	0.00011	0.00011	1.69E-12	8.14E-	0	0	0.00117	0	0	0
Hydrogen Fluoride (HF)	g	7.83E-05	5.14E-	1.34E-05	1.34E-05	2.12E-13	1.02E-	0	0	0	0	1.02E-07	0
Ammonia (NH ₃)	g	0.46877	1.05E-	1.18E-09	1.18E-09	9.76E-16	4.69E-	1.18E-07	0.46867	5.78E-07	6.67E-09	9.85E-05	0
Water Emissions													
Agrochemicals (unspecified)	g	0.06670	0	0	0	0	0	0	0	0	0	0	0.06670
BOD5 (Biochemical Oxygen Demand)	g	0.03391	0.01646	0.00429	0.00429	2.12E-12	1.02E-09	3.54E-08	0.00852	0.00030	2.39E-05	2.95E-05	0
COD (Chemical Oxygen Demand)	g	0.24044	0.13927	0.03632	0.03632	1.79E-11	8.62E-	1.06E-07	0.02568	0.00250	0.00020	0.000165	0
Metals (unspecified)	g	0.00104	0.00068	0.00018	0.00018	1.04E-13	5.00E-	0	0	0	0	0	0
Ammonia (NH ₄ ⁺ , NH ₃ , as N)	g	0.00402	0.00241	0.00063	0.00063	3.14E-13	1.51E-	2.28E-06	0.00028	4.70E-05	5.86E-06	2.05E-05	0
Nitrates (NO ₃ ⁻)	g	1.71E-05	6.51E-	1.70E-07	1.70E-07	2.68E-15	1.29E-	1.16E-06	5.47E-07	2.40E-06	1.55E-06	1.04E-05	0
Solid Waste (hazardous)	kg	8.15E-05	5.36E-	1.40E-05	1.40E-05	6.89E-15	3.31E-	0	0	0	0	0	0
Solid Waste (non-hazardous)	kg	0.003681	0.00036	9.56E-05	9.56E-05	7.27E-12	3.49E-	0.00101	0.00023	0.00081	0.00066	0.000414	0
Total Primary Energy	MJ	3.158330	1.17068	0.31419	0.31419	9.25E-05	0.04445	0.07011	0.32653	0.20804	0.12367	0.586382	0
Fossil Energy	MJ	3.137950	1.16951	0.31388	0.31388	9.25E-05	0.04445	0.06874	0.32554	0.20421	0.12089	0.576736	0

5.2 Soybean Transport to Crusher

The transport of soybeans from the field to the crusher is based on current practices in the soybean farming and soybean crushing sectors. The actual data used in this study were based on a combination of conversations with industry representatives and modeled data. We ignored transporting soybeans for the export market, which represents most of the longest transportation distances in the industry.

5.2.1 Modes of Transport and Distance Transported

Most soybean crushers are located in or near major soybean-producing regions in the 14 major soybean producing states we are modeling in this LCA. According to at least one expert, most crushing locations will receive soybeans from within a 75-mile radius⁴⁶. The average transportation distance for a radius is typically the value of the radius because of road networks and variations in terrain. We assumed that the average distance soybeans are transported from the field to a crushing location is 75 miles.

We assumed that most of the transported soybeans that move 75 miles from the field to the crusher are moved by heavy-duty trucks. No other modes were assumed to be used for these short distances. Longer distance modes such as barges and trains, are assumed to move soybeans to export markets, but would not logically be used to move soybeans 75 miles. The transportation model from DEAMTM was used to model energy requirements and emissions from truck transportation.

The moisture content of the beans being transported is 16%, based on data for beans delivered directly from the field to the crusher during the Fall harvest. In reality beans may be stored by cooperatives for extended periods of time. In this case, the beans would be dried to around 11% moisture. We consolidated all energy demand for drying at the site of the crusher. Thus, instead of receiving beans already dried to 11%, the crusher has to dry the raw beans from its harvest moisture level of 16%. From an energy balance perspective, where we take the penalty for drying has no impact.

5.2.2 Energy and Fugitive Emissions from Storage and Handling

Energy and emissions result from loading and unloading the soybeans. The loading requirements are based on the electricity required to pump 1 kg of liquid. We assumed that the same electricity is required to load 1 kg of soybeans. The energy required for unloading the soybeans is included in the soybean crushing model.

Fugitive emissions from loading, unloading, and transporting of the soybeans from the field to the crusher are not included in the model, even though they may exist. We could not find data that described these emissions.

5.2.3 Soybean Transportation Results

Table 63 shows the LCI results for soybean transportation for the transport of 1 kg of soybeans to a generic U.S. crushing location.

⁴⁶ Communications with Phil Baumel of Iowa State University.

Table 63: LCI Results for Soybean Transport (for 1 kg of soybeans)

	Units	Transport of Soybeans to Crusher	Truck Loading	Truck Transport
Raw Materials				
Coal (in ground)	kg	0.0001062	2.07E-07	0.000106
Oil (in ground)	kg	0.0033994	7.11E-09	0.0033994
Natural Gas (in ground)	kg	0.0002919	2.27E-08	0.0002919
Uranium (U, ore)	kg	2.53E-09	4.95E-12	2.53E-09
Phosphate Rock (in ground)	kg	0	0	0
Potash (K ₂ O, in ground)	kg	0	0	0
Perlite (SiO ₂ , ore)	kg	7.73E-07	0	7.73E-07
Limestone (CaCO ₃ , in ground)	kg	2.02E-05	3.94E-08	2.01E-05
Sodium Chloride (NaCl)	kg	0	0	0
Water Used (total)	liter	0.0004731	6.34E-09	0.0004731
Air Emissions				
Carbon Dioxide (CO ₂ , fossil)	g	11.3255	0.000640	11.3249
Carbon Dioxide (CO ₂ , biomass)	g	0	0	0
Methane (CH ₄)	g	0.0040585	1.54E-06	0.0040569
Nitrous Oxide (N ₂ O)	g	0.0011253	1.18E-08	0.0011253
Carbon Monoxide (CO)	g	0.0384142	1.42E-07	0.0384141
Hydrocarbons (except methane)	g	0.0082712	5.19E-09	0.0082712
Hydrocarbons (unspecified)	g	0.00448	1.69E-08	0.00448
Benzene	g	7.63E-07	0	7.63E-07
Formaldehyde	g	1.02E-05	3.33E-17	1.02E-05
Particulates (PM10)	g	0.0128418	0	0.0128418
Particulates (unspecified)	g	0.00242	2.91E-06	0.0024171
Sulfur Oxides (SO _x as SO ₂)	g	0.0166862	3.65E-06	0.0166825
Nitrogen Oxides (NO _x as NO ₂)	g	0.106559	1.99E-06	0.106557
Hydrogen Chloride (HCl)	g	5.70E-05	1.11E-07	5.69E-05
Hydrogen Fluoride (HF)	g	7.13E-06	1.39E-08	7.12E-06
Ammonia (NH ₃)	g	1.45E-08	7.60E-13	1.45E-08
Water Emissions				
Agrochemicals (unspecified)	g	0	0	0
BOD5 (Biochemical Oxygen Demand)	g	0.0022801	2.67E-09	0.0022801
COD (Chemical Oxygen Demand)	g	0.0192927	2.26E-08	0.0192927
Metals (unspecified)	g	9.43E-05	1.69E-10	9.43E-05
Ammonia (NH ₄ ⁺ , NH ₃ , as N)	g	0.0003334	6.60E-10	0.0003334
Nitrates (NO ₃ ⁻)	g	9.03E-08	1.77E-10	9.02E-08
Solid Waste (hazardous)	kg	7.42E-06	8.69E-12	7.42E-06
Solid Waste (non-hazardous)	kg	5.09E-05	7.56E-08	5.08E-05
Total Primary Energy	MJ	0.162186	1.02E-05	0.162175
Fossil Energy	MJ	0.162023	9.83E-06	0.162014

5.3 Soybean Crushing

The modeling of soybean agriculture and soybean transportation to a crushing location have been described in previous sections. This section of the report describes the system of crushing soybeans into oil and meal as shown in Figure 44:

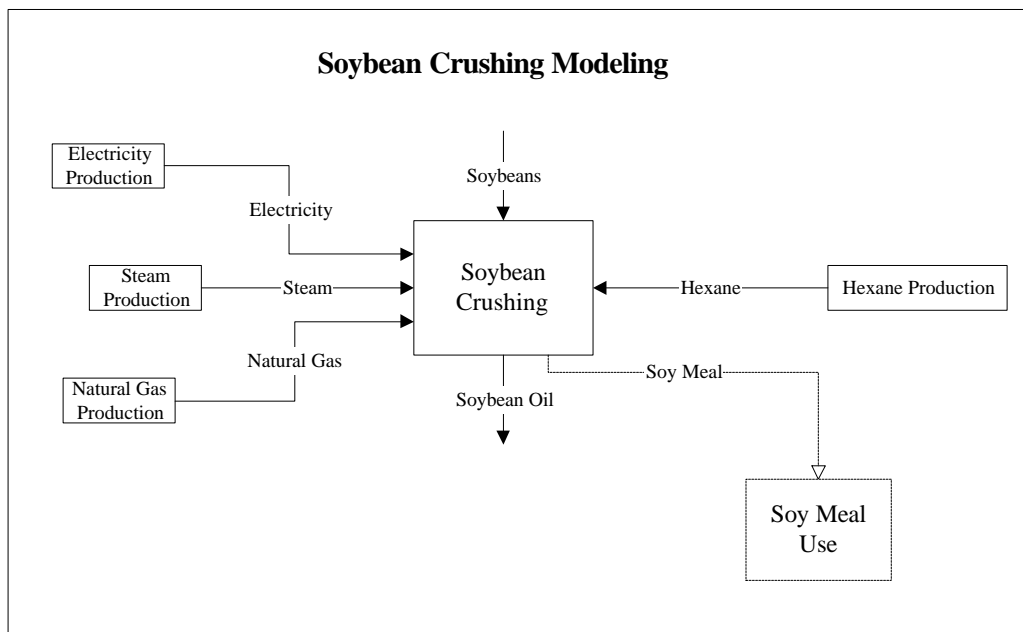

Figure 44: Soybean Crushing System Description

We modeled the soybean crushing process using, as a starting point, a detailed engineering study of a crushing facility located in the southeastern region of the United States (Adams et al 1981). The data available from this study are 17 years old. Furthermore, this study, though detailed in its analysis, represents performance of a single facility. To compensate for these limitations in the original data, an Excel® spreadsheet was developed that uses specific data from this facility in conjunction with basic engineering principles to establish a consistent set of material and energy balances for the overall process and for each of its unit operations. The result is a soybean crushing model with greater accuracy and robustness. To further ensure that our results reflect current crushing industry practice, the model output was reviewed by the National Oil Processors' Association (NOPA), the trade group representing soybean and oilseed crushers. We did, as a result of NOPA's review, adjust our estimate of a key performance parameters in the model—the thermal efficiency of the soybean dryers (discussed in more detail later in this section).

5.3.1 Process Description for Soybean Crushing

Figure 45 shows actual output from the spreadsheet model for a soybean crushing facility. The crushing process is fairly uniform throughout the industry; thus, the process modeled in this study is assumed to be representative of typical soybean crushing operations in the United States. The major distinguishing feature among the types of processes used in the U.S. crushing plants is in the oil extraction method. Our model facility uses solvent extraction to recover the oil. The alternative to solvent extraction is mechanical extraction (or some combination of mechanical and solvent extraction). Only 1% to 2% of

the soybeans processed in the United States are recovered via mechanical extraction methods⁴⁷. The model is broken out into eight separate sections. In the model's overview output in each section of the plant has total mass flow inputs and outputs shown. Logical output statements are shown as tags below each section box that indicate whether total mass balance closure is achieved for each section. This serves as a diagnostic tool for checking the validity of the model's output. In addition, at the bottom left corner in this figure, a box shows the output of a logical "if" statement, which checks for overall closure of the total plant material balance.

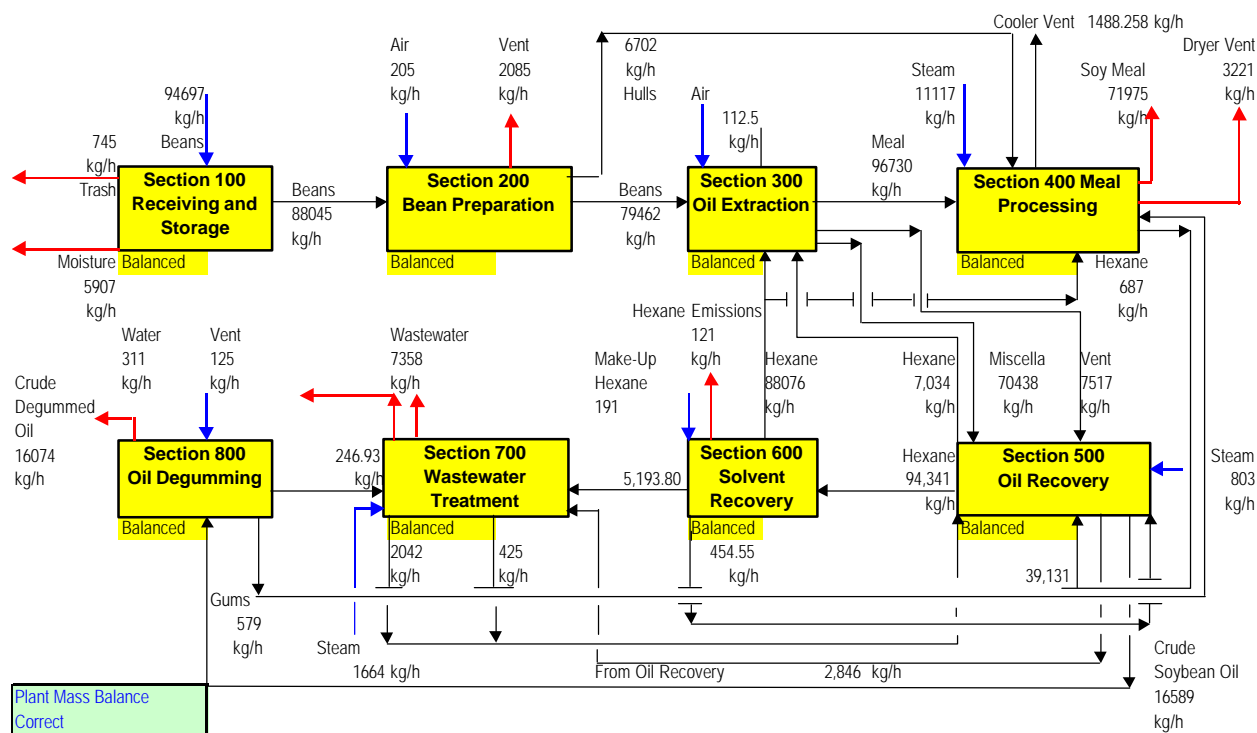

Figure 45: Overview of Soybean Crushing Process

The model assumes a facility that handles, on average, around 95,000 kg/h of soybeans (or 2,273 metric tons/day). This corresponds to almost 400 metric tons/day of crude, degummed soybean oil produced by the plant. Input to and through the receiving and storage section of the plant varies widely around the average flow of soybeans because delivery of beans to the plant is not uniform

Preparation of beans involves removal of the beans' hulls, as well as grinding and flaking. Flaked beans are then subjected to an extraction step in which hexane is used to remove the soybean oil. The extracted beans are dried and ground to produce a marketable meal product. Oil-containing hexane is then processed to separate the volatile hexane phase from the oil. Hexane solvent is recovered and recycled as much as possible. Finally the oil product is washed with water to remove gums before the final oil product is stored or shipped. Specific details for each section of the process follow.

⁴⁷ Erickson, D.R. "Chapter 5: Overview of Modern Soybean Processing," *Practical Handbook of Soybean Processing and Utilization*. AOCS Press, Champlain, IL 1995. Mechanical extraction involves use of continuous screw presses to expel oil from the beans. This approach is more energy intensive and generally more appropriate for oil seeds with higher oil contents.

5.3.1.1 Soybean Receiving and Storage

Figure 46 provides a process flow diagram for the receiving and storage section of the bean crushing plant. Once again, this diagram is actual output from the spreadsheet model. This part of the process includes conveyors for moving the beans, dryers, screens, and storage bins. Beans are received by truck. Barge access is used for moving soybean meal out of the plant. Note that the shipping of meal is not included in our LCI. The composition of the beans received is shown in Table 64 (Adams et al. 1981). Basic composition of the oil contained in the beans is shown in Table 65.

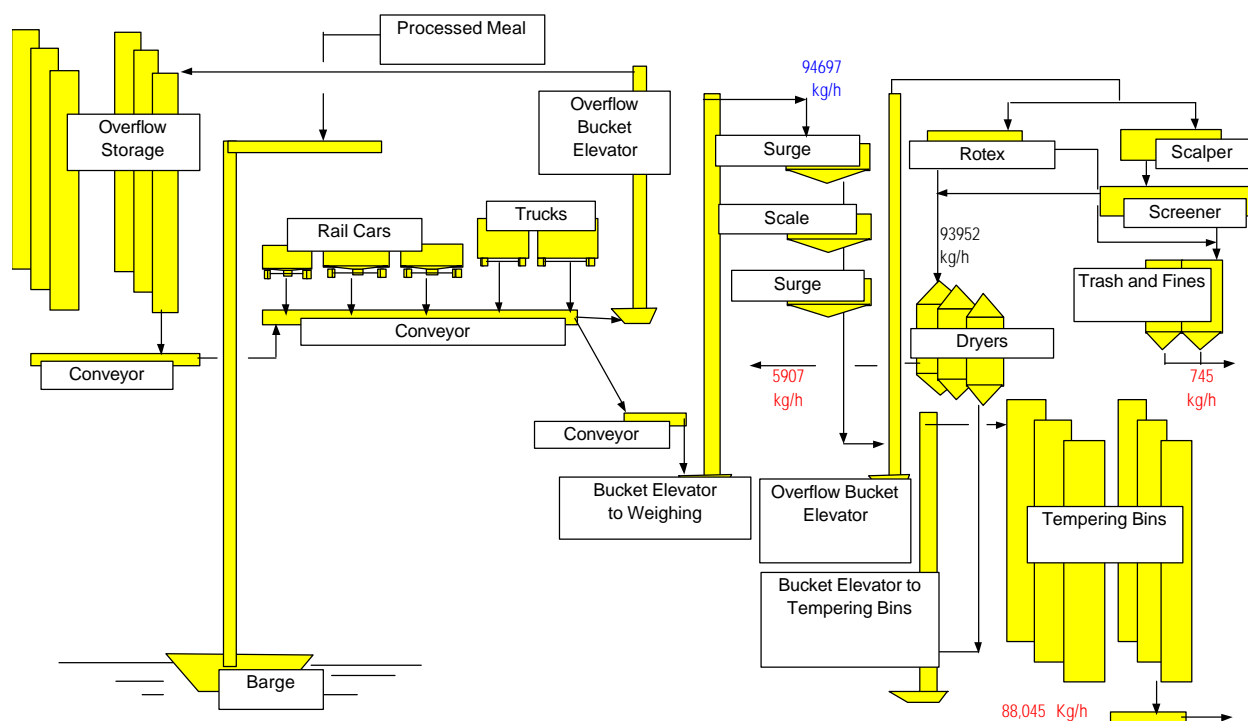

Figure 46: Receiving and Storage in Soybean Crushing Facility

Table 64: Bean Composition

Percent Oil in Beans	18.4%
Percent “Other Solids” in Beans	0.8%
Percent Hulls in Beans	7.4%
Percent Moisture in Beans	16.0%
Percent Meal in Beans	57.4%
Total	100.00%

The beans contain only 18.4% oil. The “other solids” are dirt and trash that are screened out of the beans and disposed of as waste. The triglycerides are the component of the oil that can be transesterified to

biodiesel. Free fatty acids are hydrolyzed forms of fats that are not converted to biodiesel by transesterification and that must be removed before biodiesel production. Phosphatides in the beans are more commonly referred to as “gums.” In our modeling of oil recovery and refining, we assume that these gums must also be removed before shipment to a biodiesel plant.

Moisture content of the beans can range from 14% to 18% in the Fall harvest delivered to the facility. The beans in our model facility are dried from a moisture content of 16% to a level of 10.5%. This moisture level is optimal for cracking the beans later in the process, and ensures that, under conditions of extended storage, the beans will not deteriorate appreciably.

Table 65: Soybean Oil Composition⁴⁸

Triglycerides	95.20%
Phosphatides (Gums)	2.50%
Unsaponifiable Matter	1.60%
Free Fatty Acids	0.70%
Total	100.00%

Figure 46 provides mass flows in and out of all major equipment in this section of the crushing operation. Of the 94,697 kg/h of beans delivered to the plant, 88,045 kg/h (or 93%) remain after dirt, trash, and moisture are removed. Energy requirements for this part of the plant are based on equipment power ratings and percent on-line times reported for the southeast U.S. facility (Adams et al. 1981). In addition, energy requirements for removing moisture are calculated for the air drying systems. Heat is supplied to the dryers by combustion of natural gas. The dryer is assumed to require 1940 kcal/kg (3500 Btu/lb) of water removed⁴⁹. The latent heat of vaporization is only 610 kcal/kg (1100 Btu/lb). This corresponds to an efficiency of 31% for the dryer.

Energy requirements are summarized in Table 66. Drying of the beans is one of the most energy-intensive parts of the process.

5.3.1.2 Bean Preparation

Mechanical processing of beans before extraction involves cracking of the beans followed by dehulling, cracking, conditioning and flaking (Figure 47). The five cracking rollers break up the beans into six to eight pieces. Dehulling does not provide a perfect separation between what the industry calls the “meats” of the beans and the hulls. Meats include the meal, oil, and moisture. One percent of the hulls remains with the meats. Seven percent of the meats is lost with the separated hulls. After dehulling, aspirators pneumatically carry hulls to the meal processing part of the plant. Conditioning the beans adjusts their temperature and moisture to make them more plastic and pliable before flaking. Indirect heating with steam and addition of air reduces the moisture content to 9% and raises their temperature from 21°C to

⁴⁸ Adapted from Perkins, E. “Chapter 2: Composition of Soybeans and Soybean Products,” In Erickson, DR., ed., *Practical Handbook of Soybean Processing and Utilization*, AOCS Press, Champlain, IL, 1995. This composition is for what is referred to as “crude oil”, the product of solvent extraction without any further refining.

⁴⁹ Woerfel reports that “reasonably efficient” dryers will require 830 kcal/kg (1500 Btu/lb) to 890 kcal/kg (1,600 Btu/lb) for whole bean drying (Woerfel 1995). We found higher numbers reported for drying soybean meal in Perry and Chilton 1975. However, after review of this report by the National Oil Processors’ Association (NOPA), we selected an energy demand of 1940 kcal/kg (3500 Btu/l). NOPA felt that colder temperatures often reduce the energy efficiency of these dryers to this level of 31%.

74°C. The moisture content of 9% is at the low end of the required range of 9% to 11% reported in the literature. Flaking is a critical step. Properly flaked beans must be 0.3 to 0.4 mm in thickness. Average diameter of the flakes must be such that 80% of the flakes are retained by a number 8 screen. Proper sizing of the flakes is critical to optimal extraction of the oil.

Table 66: Energy Requirements for Receiving and Storage in a Soybean Crushing Facility (normalized to 1 metric ton of beans)

Electricity (kWh)	
Rail and Truck	1.86
Cleaning	3.98
Drying	15.5
Total Electricity	21.3
Natural Gas (kcal)	
Drying	266,275

As the mass flow data show, 90% of the incoming mass of beans are sent on to extraction; 7.6% of the mass leaves with the hulls sent to the meal processing section of the plant. This is the first step where oil losses occur. Approximately 0.58% of the incoming triglycerides is lost at this stage because of the carryover of the “meats” with the hulls. The remainder of the mass balance is accounted for in additional moisture removal.

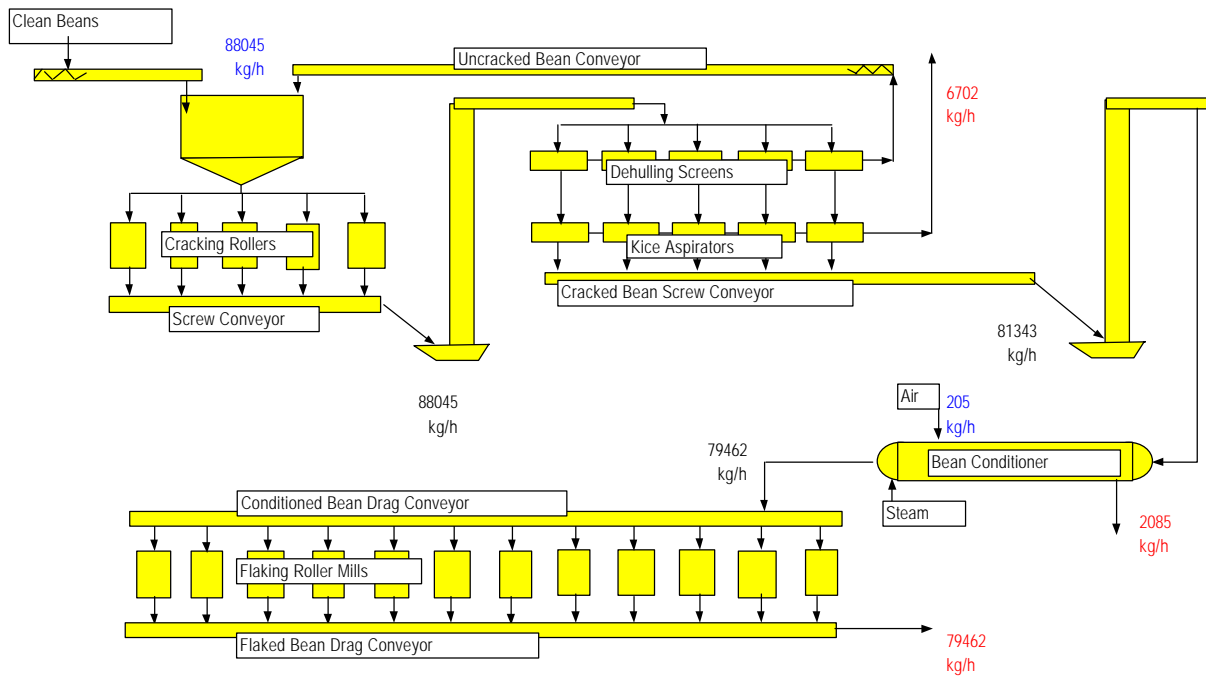

Figure 47: Bean Preparation in Soybean Crushing Facility

As in the receiving and storage section of the plant, energy requirements are estimated using the power ratings and percent on-line times from the southeastern U.S. facility. Steam requirements for bean conditioning are based on sensible heat and latent heats of vaporization for the beans, water, and air. Energy requirements are summarized in Table 67.

Table 67: Energy Requirements for Bean Preparation in a Soybean Crushing Facility (normalized per metric ton beans)

Electricity (kWh)	
Cracking	4.14
Dehulling	2.36
Conditioning	1.13
Flaking	13.96
Total Electricity	21.59
Steam (kcal)	
Conditioning	41,431

5.3.1.3 Soybean Oil Extraction

Figure 48 shows the process flow diagram for the oil extraction section of the crushing facility. The heart of this part of the process is the extractor. Four types of extractors are marketed in the industry: Rotary or deep-bed, horizontal belt, continuous loop extractors, and a miscellaneous collection of designs. The extractor used in our model is based on the one used in the southeast U.S. facility (Adams et al. 1981), and is known as a “stationary basket extractor.” It is manufactured and sold by the French Oil Mill Machinery company. It falls into the rotary bed design category. Flaked beans are dropped into a series of baskets. Miscella (the hexane/oil mixture) and hexane are pumped to the baskets to achieve a countercurrent scheme. It provides a countercurrent extraction scheme by rotating the solvent and solvent/oil mixture around the series of baskets. Each basket is washed by successively less concentrated oil/solvent mixtures, until each is ultimately washed with fresh solvent. The full miscella leaving the extractor can contain 19% to 24% oil. From our material balance, we calculate an oil content of 23.5%.

The full miscella is sent through a liquid cyclone that uses fresh hexane to remove entrained fines so that a clear miscella can then be sent on to the recovery section of the plant. The yield of oil recovered across the extraction section is 96%, providing a cumulative yield (up to this point in the plant) of 95.4% for oil. The yield of triglycerides is the same as for total oil. The rate of solvent addition is assumed to be 1.2 kg of solvent for every kg of flaked beans. Most of this solvent is recovered and recycled, so that actual make-up hexane usage is only 0.0024 kg/kg of flaked beans. Extracted flakes are dropped into a screw conveyor for subsequent removal of solvent.

Energy requirements for this section of the plant are low. Extensive heat integration is used so that heating of the solvent can be achieved using steam and energy from other parts of the plant. Electricity use amounts to a total of 3.6 kWh/metric ton of beans coming into the plant.

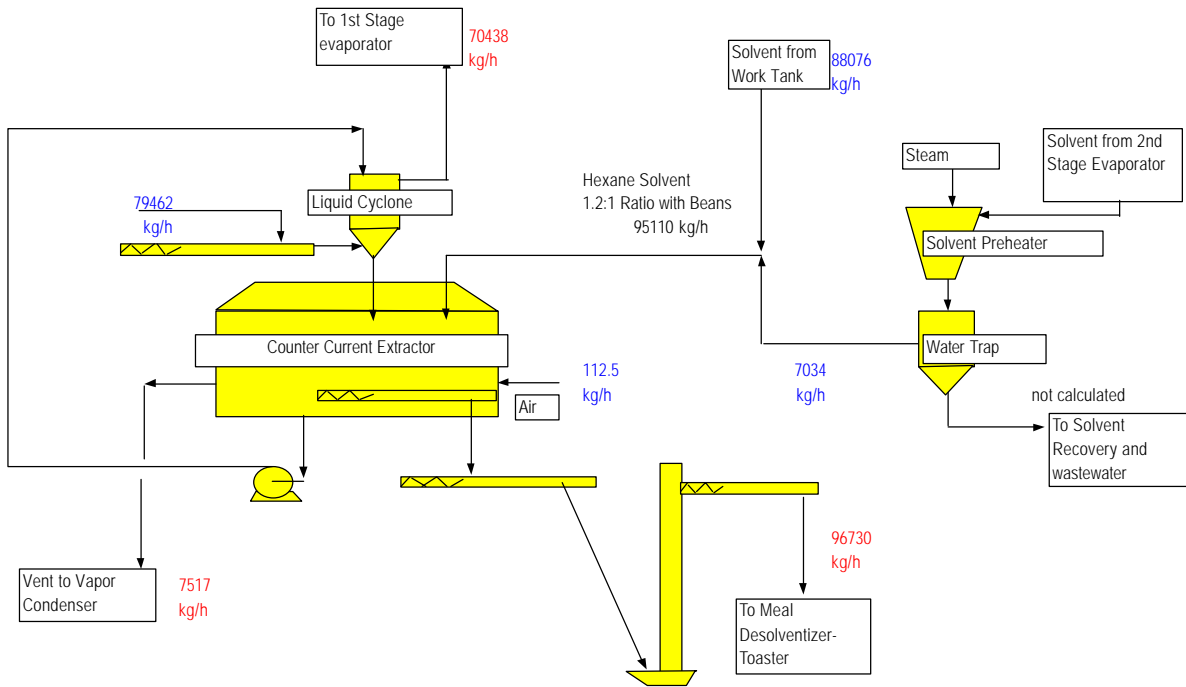

Figure 48: Oil Extraction in Soybean Crushing Facility

5.3.1.4 Meal Processing

Figure 49 shows the process flow diagram for the meal processing part of the plant. Wet solvent-containing flakes are reported to be as much as 40% hexane by weight in the southeast U.S. plant used as a starting point for our model. For the solvent application rate assumed, we calculated a hexane content of 35% by weight. These flakes are sent to a desolventizer-toaster, which does exactly what its name implies. This piece of equipment is designed to remove hexane by contacting the flakes with open steam. The flakes are toasted by contact with a series of high-temperature trays heated indirectly with high-pressure steam. Careful control of time, temperature, and moisture content in this unit is required to produce a meal essentially free of hexane and to inactivate urease and trypsin inhibitor enzymes present in the meal. Open steam is used to raise the moisture content to 20% on one of the trays; but final moisture content leaving the unit is 18%. Hexane concentration leaving the desolventizer-toaster is 995 ppm. The meal dryer uses indirect steam to reduce moisture content to a level of 14% and hexane to a level of 500 ppm. The meal is then cooled with air. Moisture content is further reduced at this point to 12%. Residual hexane is 400 ppm. The meal is then ground and conveyed to final storage and shipment. This part of the facility receives the hulls from the bean preparation part of the plant. The hulls are also toasted to inactivate the urease and trypsin enzymes. After grinding, the hulls are combined with the meal.

This part of the plant is the most energy intensive. Heating requirements for solvent removal and drying of the meal are the main contributors. All heat for this part of the plant is supplied by steam (both directly and indirectly through heat exchangers). The energy requirements are summarized in Table 68 and Table 69.

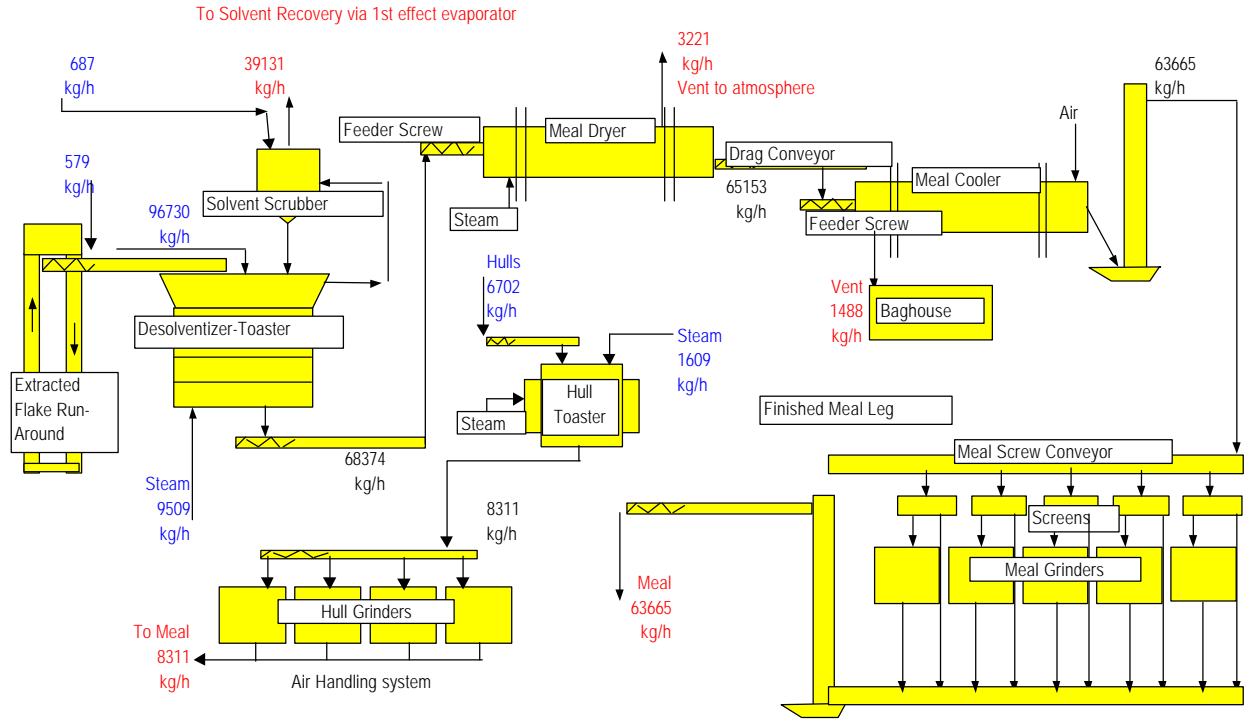

Figure 49: Meal Processing in Soybean Crushing Facility

Table 68: Electricity Requirements for Meal Processing in a Soybean Crushing Facility (kWh per metric ton of beans)

Desolventizer-Toaster	4.14
Meal Dryer	0.64
Meal Cooler	2.54
Meal Grinding	7.24
Hull Grinding	5.40
Total Electricity	19.96

Table 69: Steam Requirements for Meal Processing in a Soybean Crushing Facility (kcal per metric ton of beans)

Desolventizer-Toaster	100,824
Meal Dryer	20,546
Hull Toaster	11,704
Total Steam	133,074

5.3.1.5 Soybean Oil Recovery

Multiple effect evaporators are used to concentrate the oil in the miscella exiting the countercurrent extractor. Because of the complexity of designing the multiple effect evaporators, we used the conditions for oil concentration and temperature indicated for the system used in the southeast U.S. facility. Given these conditions, we then calculated all material and energy balances. No oil losses occur in this section of the facility. It is in this part of the facility that some of the heat integration opportunities can be recognized.

For example, hexane vapor coming from the first desolventizer-toaster in the meal processing section provides all the heat to the first stage evaporator. Most heat required for the extractor is, in turn, provided directly from the hexane vapor exiting the second stage evaporator. Steam used in the second stage evaporator and the final oil stripper are the original sources of heat that drive the extraction process. Because of environmental and economic reasons, hexane is recovered extensively from vents throughout the facility. Most of these come together at the excess vapor condenser shown in Figure 50. No appreciable oil losses occur in this section. Direct injection of steam reduces hexane content of the soybean oil to 120 ppm. Energy requirements are summarized in Table 70 and Table 71.

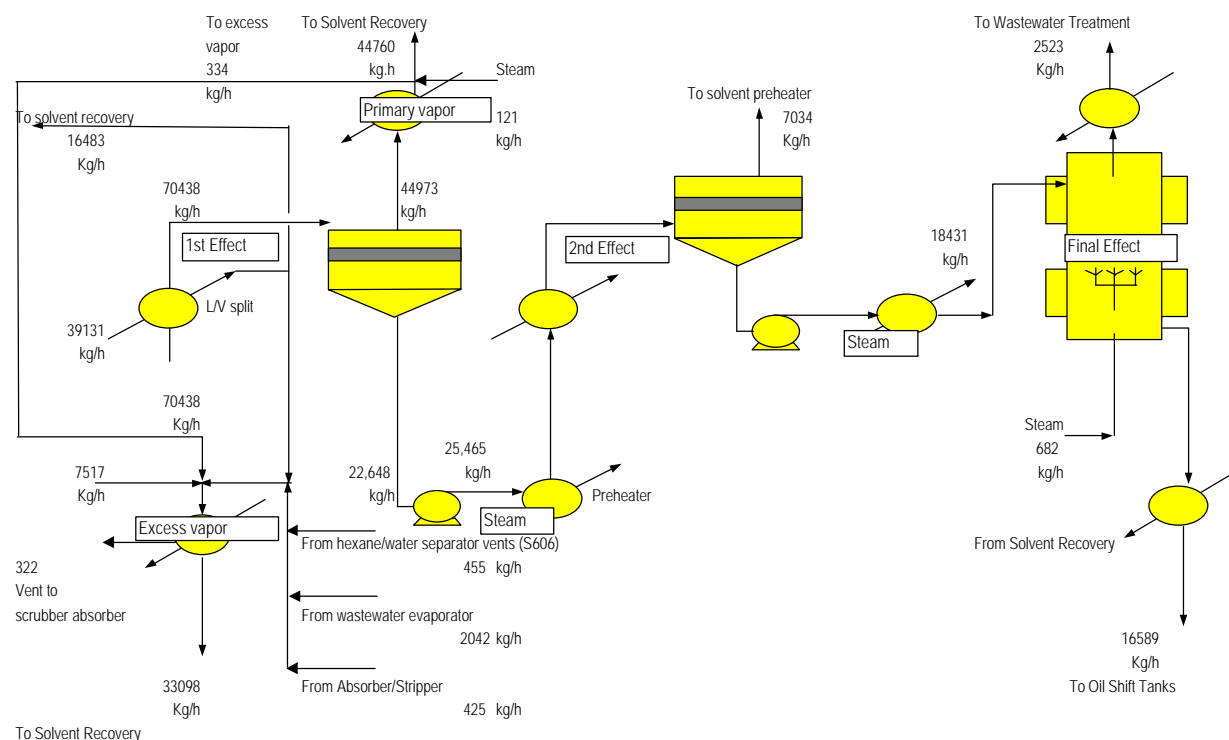

Figure 50: Oil Recovery in Soybean Crushing Facility

**Table 70: Electricity Requirements for Oil Recovery in a Soybean Crushing Facility
(kWh per metric ton of beans)**

First Effect Evaporator	0.15
Second Effect Evaporator	0.15
Final Effect Evaporator	0.08
Total Electricity	0.38

**Table 71: Steam Requirements for Oil Recovery in a Soybean Crushing Facility
(kcal per metric ton of beans)**

First Effect Evaporator	0
Second Effect Evaporator	9,978
Final Effect Evaporator	10,836
Total Steam	20,814

5.3.1.6 Solvent Recovery

Figure 51 shows the process flow diagram for recovery and recycle of hexane. Hexane and hexane/water condensate from the excess vapor condenser and other parts of the oil recovery system are sent to a settling tank. Solvent is continuously drawn off the top phase and pumped back to extraction section of the plant. The water phase is pumped to the waste treatment section of the facility. A small amount of hexane is pumped to the scrubber above the desolventizer-toaster, where it is used to remove entrained fines. Energy requirements for this section of the plant are only 0.52 kWh/metric ton of soybeans.

5.3.1.7 Oil Degumming

Degumming removes phosphatides and some of the unsaponifiable matter from the crude oil (Figure 52). This is done simply by mixing the oil with hot water. As the gums are hydrated they swell and can be separated from the oil by the difference in density. Water is added at a rate of 75% of the level of phosphatides present in the oil. A centrifuge is used to separate the hydrated gums from the oil. The oil is vacuum dried and sent to storage for shipment. The gums collected in the aqueous phase are separated from the water and sent to meal processing, where they are added to the desolventizer-toaster. Oil losses in this section of the plant are 3.11%; but only 0.5% loss of triglycerides occurs. The final yield of crude, degummed oil is 92.5% of the oil contained in the delivered beans. The yield of triglycerides is 95%. Final composition of the crude, degummed oil is shown in Table 72. The energy requirements for degumming are shown in Table 73 and Table 74.

Table 72: Final Composition of Crude, Degummed Oil

Triglycerides	97.43%
Unaponified Matter	1.500%
Free Fatty Acids	0.750%
Other	0.300%
Phosphatides (Gums)	0.0200%
Total	100.00%

Table 73: Electricity Requirements for Degumming in a Soybean Crushing Facility (kWh per metric ton of beans)

Hydration	0.24
Centrifuge	0.68
Vacuum Dryer	0.77
Total Electricity	1.69

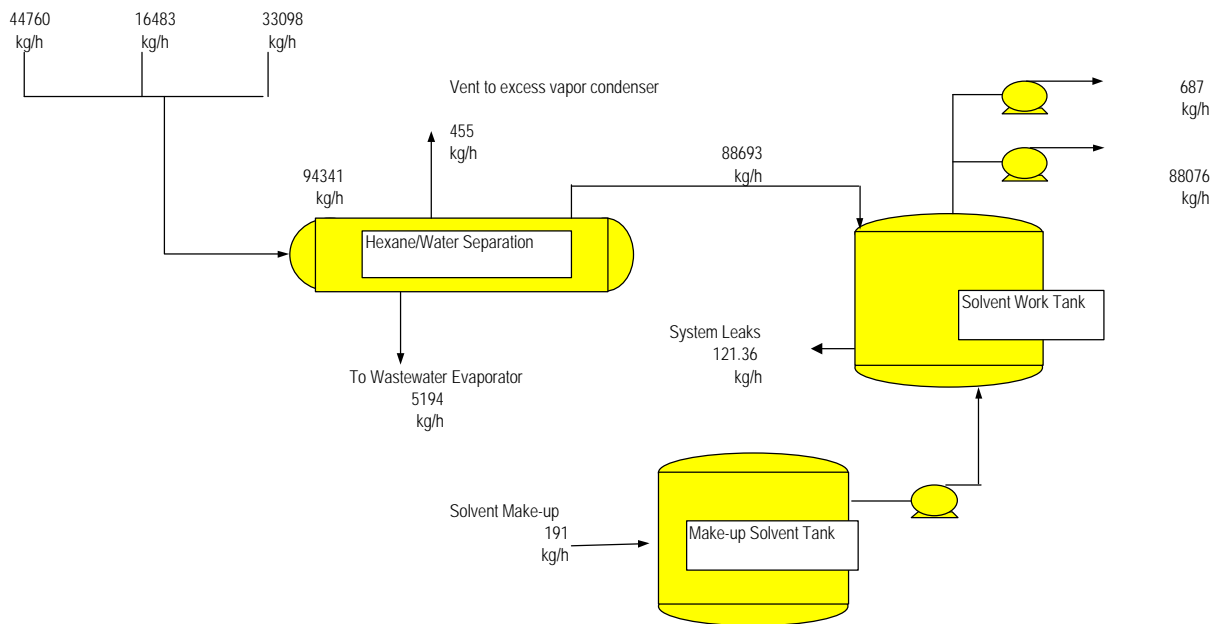

Figure 51: Solvent Recovery in Soybean Crushing Facility

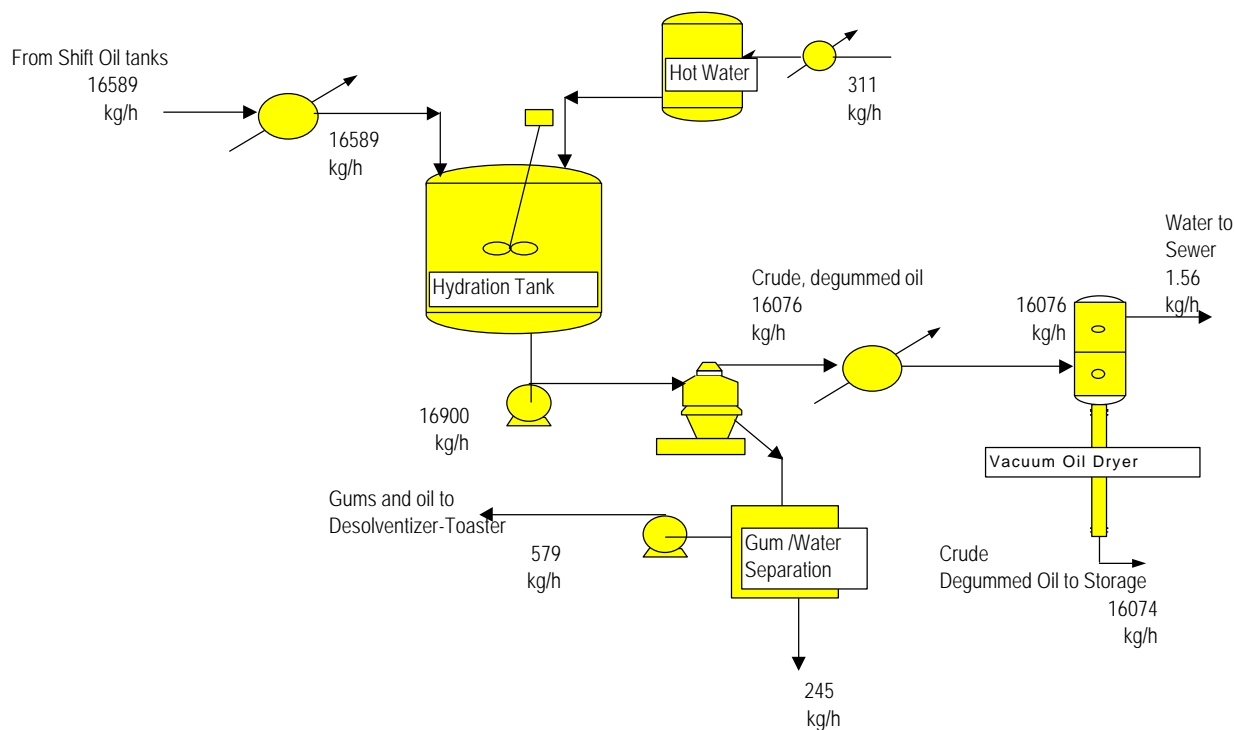

Figure 52: Oil Degumming Process for Soybean Crushing Facility

**Table 74: Steam Requirements for Degumming in a Soybean Crushing Facility
(kcal per metric ton of beans)**

Hydration	8,611
Dryer	7,743
Total Steam	16,354

5.3.1.8 Waste Treatment

Waste treatment is focused primarily on recovery of residual hexane (Figure 53). To this end, a steam stripper is used to remove evaporated hexane that is then recovered in the excess vapor condenser in the solvent recovery section of the plant. The wastewater from the evaporator contains low levels of oil from the degumming operation. The vapor that remains from the excess vapor condenser is sent to an absorber to capture any residual hexane before venting. Hexane is recovered from the absorbent by steam stripping.

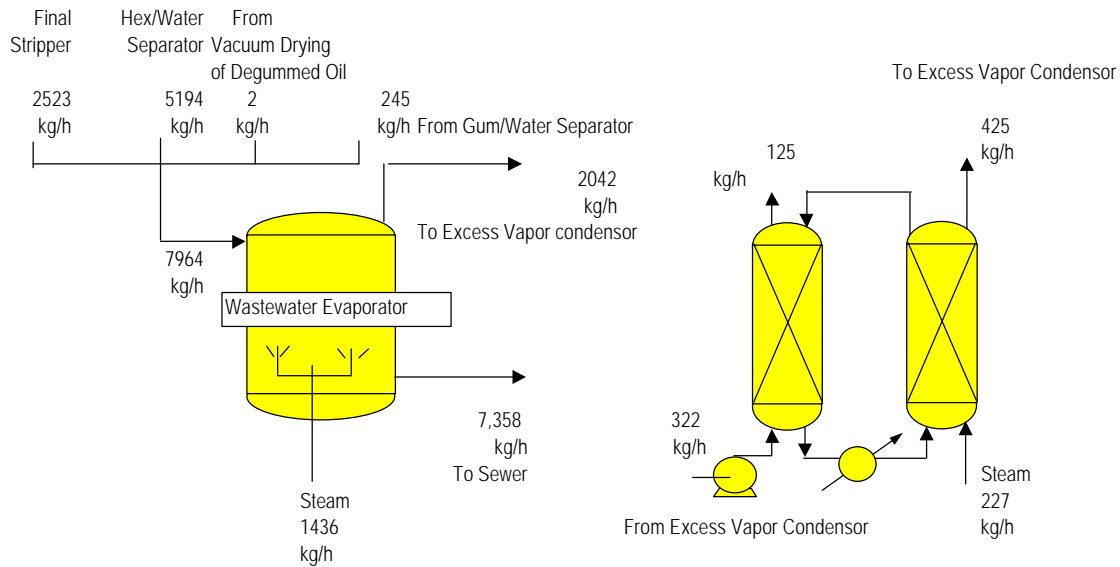

Figure 53: Waste Treatment for Soybean Crushing Facility

Electricity requirements for this section of the plant are 0.52 kWh/metric ton of beans delivered to the plant. Steam requirements are shown in Table 75.

Table 75: Steam Requirements for Waste Treatment in a Soybean Crushing Facility (kcal per metric ton of beans)

Hexane Absorption	7,207
Wastewater Evaporator	1,591
Total Steam	8,798

5.3.2 Analysis of Yields and Energy Balance

Yield results for each section of the plant are shown in Figure 54. Crude oil and triglycerides are shown. The most significant for biodiesel production is the yield of triglycerides, because these are the components of the oil that are transesterified.

As Figure 54 shows, the performance of the extractor is the most critical part of the process in determining yield of triglycerides from soybeans. Minor losses occur in the bean preparation and in the oil degumming steps. The difference between 95% yield of triglycerides and the 92% yield of total oil from the facility is due to the removal of gums and unsaponifiable matter.

A comparison of electricity demands in various parts of the crushing operation is shown in Table 76 and Figure 55. Electricity demand is dominated by solids handling and size reduction equipment. These occur in the receiving and storage, bean preparation, and meal processing sections of the plants. Steam and natural gas demand, used primarily for heating, are summarized in Figure 56.

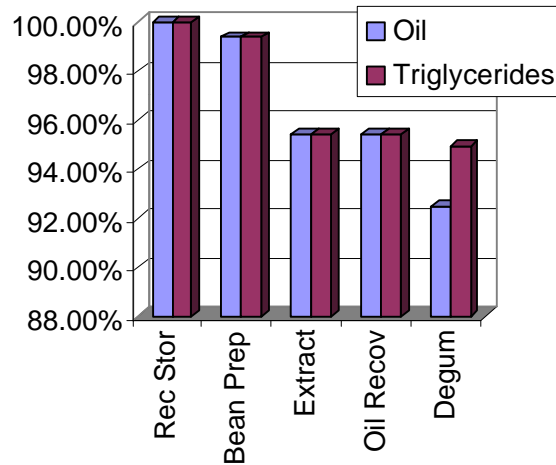

Figure 54: Yield of Oil and Triglycerides in a Soybean Crushing Facility

Table 76: Summary of Electricity Requirements for Soybean Crushing (kWh per metric ton of beans)

Section	Electricity Requirements
Oil Recovery	0.38
Solvent Recovery	0.52
Waste Treatment	0.57
Degumming	1.69
Oil Extraction	3.60
Meal Processing	19.95
Receiving and Storage	21.35
Bean Preparation	21.59
Total	69.65

All the energy shown in Figure 56 is for steam usage except for the receiving and storage number, which includes only the energy used in burning natural gas to dry beans before storage. Once again, receiving and storage, bean preparation, and meal processing are the dominant consumers of energy from steam and natural gas. Oil recovery and oil degumming also use significant amounts of energy.

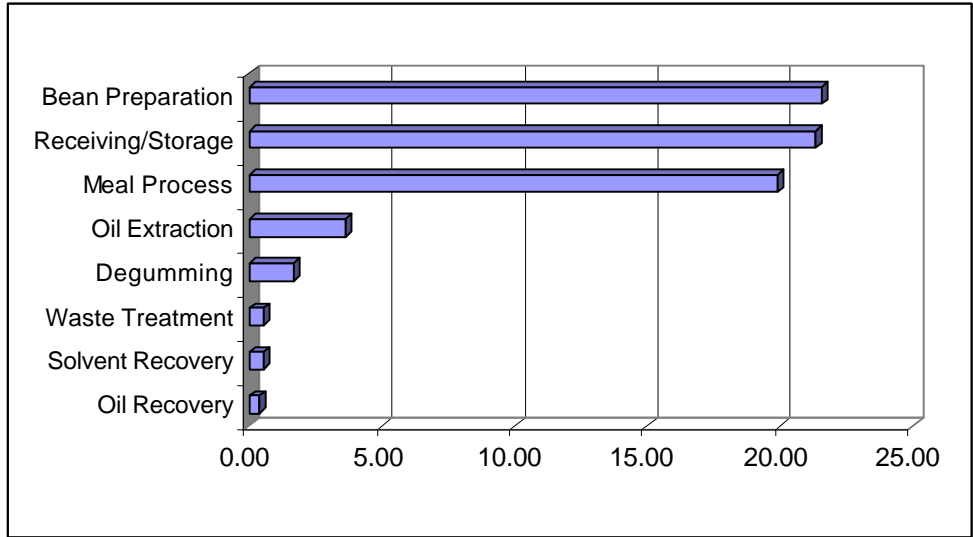

Figure 55: Distribution of Electricity Requirements in a Soybean Crushing Facility (kWh per metric ton of beans)

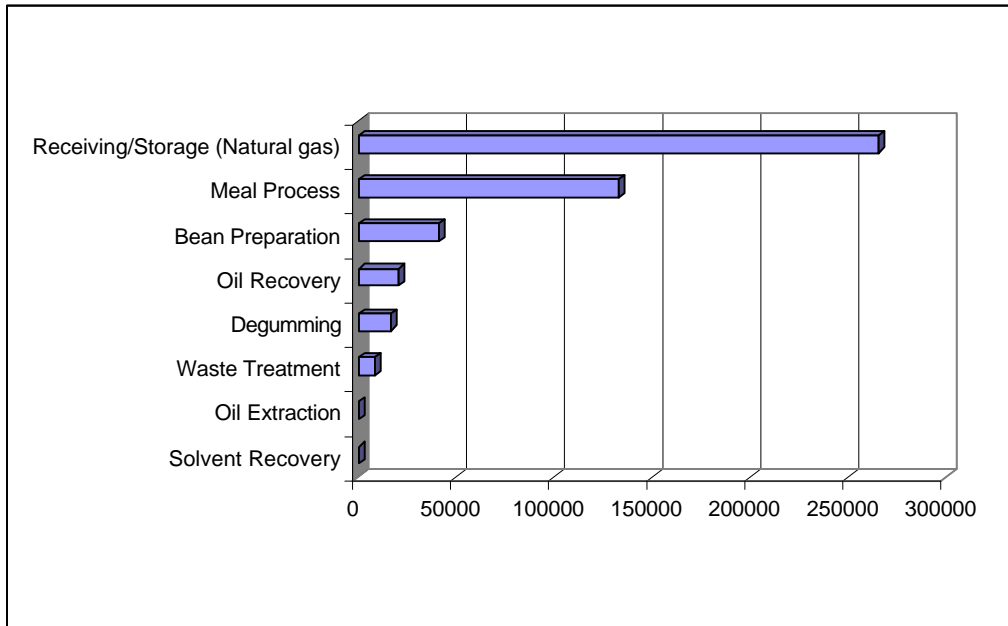

Figure 56: Steam and Natural Gas Consumption in a Soybean Crushing Facility (kcal per metric ton of beans)

5.3.3 Overall Inputs to Soybean Crushing

The soybean crushing facility has only three raw material inputs (see Table 77): soybeans, hexane, and water. The inputs are shown below for actual hourly flow of the model crushing facility, as well as in normalized units (per metric ton of beans delivered and oil produced).

Table 77: Raw Material Inputs to Soybean Crushing Facility

Component	Hourly Flow (kg/h)	kg/Metric Ton of Beans Delivered	kg/Metric Ton of Oil Produced
Soybeans	94,697	1,000	5,891.27
Hexane	191.	2.02	11.90
Water	311	3.28	19.35

Energy inputs to the soybean crushing facility are summarized in Table 78. They are listed according to the form of energy used and normalized to the amount of delivered beans and oil produced. In our Ecobalance model, the electricity demand presented here is tied back to an electricity model describing electricity produced on a generic (national average) U.S. grid. Similarly, steam demand is tied back to an Ecobalance module describing a natural gas-fired industrial boiler. National average data for natural gas production are used to model life cycle flows from production and distribution of natural gas.

Table 78: Energy Inputs to Soybean Crushing Process

Energy Source	Energy per Metric Ton of Beans Delivered	Energy per Metric Ton of Oil Produced
Electricity (kWh)	69.66	410.45
Natural Gas (kcal)	266,275	1,568,858.71
Steam (kcal)	220,020	1,296,331.52

5.3.4 Overall Soybean Crushing Outputs

Products from the crushing facility are indicated in Table 79. The only two products from this operation are soybean meal and soybean oil. Of 1,000 kg of beans going into the process, 760 kg end up as meal and 170 kg end up as crude, degummed soybean oil. The remaining 70 kg is accounted for in air, solid, and liquid waste streams.

Table 79: Products from Soybean Crushing Facility

Product	Hourly Flow (kg/h)	Kg per Metric Ton of Beans Delivered	Kg per Metric Ton of Oil Produced
Crude, Degummed Soybean Oil	16,072.45	169.73	1,000.00
Soybean Meal	71,975.40	760.06	4,478.19

Air emissions from the facility are summarized in Table 80. Hexane emissions come from vent losses in meal processing and solvent recovery. Soybean crushing facilities assiduously recycle the hexane used in the process. The need for hexane make-up reflects the small losses that occur in these plants. The hexane shown as an air emission in Table 80 accounts for 163 kg/h of the 191 kg/h required as make-up feed to the process. The remaining 28 kg/h of hexane loss can be accounted for in low levels of residual hexane contained in the oil and meal products. Water vapor leaving in vents is almost exclusively the result of

drying steps to remove moisture contained in the beans. Emissions from combustion are estimated using data from the DEAM™ database. These emissions are associated with combustion of natural gas to produce steam and hot air for drying.

Table 80: Air Emissions from Soybean Crushing Facility (Excluding Combustion)

Component	Hourly Flow (kg/h)	kg per Metric Ton of Beans Delivered	kg per Metric Ton of Oil Produced
Moisture	6,561	69.28	408.19
Air	317	3.35	19.73
Hexane	163	1.72	10.15

Water emissions are indicated in Table 81. An explicit material balance for water in and out of the process has not been shown (though a complete material balance has been achieved for the crushing process). For example, a quick inspection of the water input shown in Table 77 and water leaving as waste in Table 81 reveals that water leaving as waste is much greater than the amount of process water brought in. The added flow of water is due to the use of steam injected directly into the process streams. This steam condenses and ultimately ends up as wastewater. The steam flows presented in the energy inputs (Table 78) include steam used for indirect heat exchange as well as steam directly injected into the process. The detailed spreadsheet model for crushing correctly accounts for steam, which becomes part of the process flows in the material balance. The primary contaminant of the wastewater is soybean oil. The oil is present at a level of 1.1% by weight of the total wastewater flow. In section 5.3.2, we indicated that the total yield of oil from the crushing process is 92.5%. Approximately 0.5% of the oil contained in the beans is lost as part of the wastewater discharge. The remaining 7% of the oil present in the beans can be accounted for as residual oil in the meal product.

Table 81: Water Emissions from a Soybean Crushing Facility

Component	Wastewater kg/h	kg per Metric Ton of Beans Delivered	kg per Metric Ton of Soybean Oil Produced
Total Wastewater	7,358.26	77.70	457.77
Soybean Oil	80.77	0.85	5.02
Triglycerides	78.96	0.83	4.91
Phosphatides	0.02	0.0002	0.00
Unsaponifiable Matter	1.21	0.01	0.08
Free Fatty Acids	0.58	0.01	0.04
Moisture	7,277.50	76.85	452.75

The only solid waste generated in the soybean crushing operation is from trash and tramp metals removed from the raw beans. This amounts to 745 kg/h of total flow (0.008 kg/kg of raw beans delivered or 0.046 kg per kg of degummed oil produced). In the LCI, this trash is categorized as nonhazardous waste.

5.3.5 Allocation of Life Cycle Flows for Soybean Crushing

Soybean crushing facilities produce both soybean oil and soybean meal. This study is concerned only with the production of soybean oil. Therefore, there needs to be a method of allocating total crushing energy use and total crushing emissions to the production of soybean oil only.

An allocation technique based on the mass output of soybean crushing is used as the baseline for this study. In order to allocate total soybean crushing environmental flows among the products on a mass output basis, the mass percent of each coproduct must be known. Table 82 outlines how this would be done, based on the output of a generic soybean crushing facility. The percentages are based on the product outputs described in section 5.3.4.

Table 82: Production of a Generic Soybean Crushing Facility

	Mass (kg/h)	Mass (%)
Soybean Oil	16,072	18 %
Soybean Meal	71,975	82 %
Total	88,047	100%

5.3.6 Soybean Crushing Results

Table 83 shows the LCI results for soybean crushing for the production of 1 kg of soybean oil. These results are output from the Ecobalance model. Thus, the emissions and flows shown in the first column reflect indirect flows coming from intermediate raw material and energy inputs to the crushing operation, as well as the direct flows discussed in sections 5.3.1 through 5.3.5. This subtle distinction becomes apparent when you consider some of the water and solid waste flows listed in this table. For example BOD₅ and COD numbers appear, even though no estimates for these flows are provided in our model for soybean crushing. These components enter the LCI as a result of electricity generation and the production of other raw materials used in the crushing operation. Similarly, no hazardous waste is generated in the crushing facility. The small amount shown in Table 83 is the result of indirect contributions from other processes.

Table 83: LCI Results for Soybean Crushing (for 1 kg of soybean oil)

	Units	Total Soybean Crushing	Natural Gas Use	Steam Production	Electricity Production	Hexane Production	Direct from Crushing
Raw Materials							
Coal (in ground)	kg	0.018566	4.19E-08	4.33E-08	0.0185663	1.82E-09	0
Oil (in ground)	kg	0.002991	5.47E-08	5.65E-08	0.0006388	0.0023523	0
Natural Gas (in ground)	kg	0.050306	0.02374	0.0245249	0.0020365	1.50E-08	0
Uranium (U, ore)	kg	4.45E-07	1.00E-12	1.04E-12	4.45E-07	0	0
Phosphate Rock (in ground)	kg	0	0	0	0	0	0
Potash (K ₂ O, in ground)	kg	0	0	0	0	0	0
Perlite (SiO ₂ , ore)	kg	0	0	0	0	0	0
Limestone (CaCO ₃ , in ground)	kg	0.00354	7.95E-09	8.21E-09	0.0035403	0	0
Sodium Chloride (NaCl)	kg	0	0	0	0	0	0
Water Used (total)	liter	0.004097	6.74E-09	6.96E-09	0.0005701	0	0.00353
Air Emissions							
Carbon Dioxide (CO ₂ , fossil)	g	200.328	69.9311	72.2291	57.519	0.649155	0
Carbon Dioxide (CO ₂ , biomass)	g	na	na	na	na	na	na
Methane (CH ₄)	g	0.37326	0.1154	0.119192	0.138668	9.77E-08	0
Nitrous Oxide (N ₂ O)	g	0.001814	0.00032	0.0003303	0.0010621	0.0001015	0
Carbon Monoxide (CO)	g	0.060743	0.02334	0.0241107	0.0127441	0.0005446	0
Hydrocarbons (except methane)	g	1.86624	0.0008	0.0008255	0.0004664	0.0147412	1.84941
Hydrocarbons (unspecified)	g	0.001518	4.77E-07	4.93E-07	0.0015171	0	0
Benzene	g	0	0	0	0	0	0
Formaldehyde	g	3.00E-12	6.66E-17	6.88E-17	3.00E-12	0	0
Particulates (PM10)	g	0.003411	0.00168	0.001733	0	0	0
Particulates (unspecified)	g	0.261845	4.26E-05	4.40E-05	0.261279	0.00048	0
Sulfur Oxides (SO _x as SO ₂)	g	1.43078	0.53839	0.556078	0.327924	0.0083909	0
Nitrogen Oxides (NO _x as NO ₂)	g	0.375724	0.09502	0.0981413	0.178429	0.0041355	0
Hydrogen Chloride (HCl)	g	0.010019	2.26E-08	2.34E-08	0.0100188	0	0
Hydrogen Fluoride (HF)	g	0.001252	2.83E-09	2.92E-09	0.0012524	0	0
Ammonia (NH ₃)	g	4.62E-05	1.30E-11	1.35E-11	6.83E-08	4.62E-05	0
Water Emissions							
Agrochemicals (unspecified)	g	0	0	0	0	0	0
BOD5 (Biochemical Oxygen Demand)	g	0.000253	2.83E-08	2.92E-08	0.0002399	1.30E-05	0
COD (Chemical Oxygen Demand)	g	0.002069	2.39E-07	2.47E-07	0.0020298	3.91E-05	0
Metals (unspecified)	g	1.52E-05	1.39E-09	1.43E-09	1.52E-05	0	0
Ammonia (NH ₄ ⁺ , NH ₃ , as N)	g	5.93E-05	4.19E-09	4.33E-09	5.93E-05	0	0
Nitrates (NO ₃ ⁻)	g	1.59E-05	3.58E-11	3.70E-11	1.59E-05	0	0
Solid Waste (hazardous)	kg	7.81E-07	9.20E-11	9.51E-11	7.81E-07	0	0
Solid Waste (nonhazardous)	kg	0.015261	9.71E-08	1.00E-07	0.0067949	3.41E-06	0.00846
Total Primary Energy	MJ	3.47122	1.23473	1.2753	0.912304	0.048883	0
Fossil Energy	MJ	3.44276	1.23473	1.2753	0.883847	0.048883	0

5.4 Soybean Oil Transport

This section describes the assumptions behind determining the distances and locations soy oil is transported, and discusses the data used to model the environmental flows associated with these activities.

5.4.1 Where Do We Locate the Biodiesel Conversion Facilities?

In order to model the transport of soybean oil to the biodiesel production facility, we needed to postulate the location of these biodiesel facilities in the near future. Our basic choices were: (1) move soy oil to the retail market where biodiesel is made, (2) make the biodiesel at the crushing plant and move biodiesel to the retail market, or (3) transport soy oil to a biodiesel plant located some where between the crusher and the retail market. Regardless of the scenario we choose, we still model the transport of the same liquid mass over the same total distance⁵⁰. This is an important assumption on our part, but it appears to be fairly robust.⁵¹ Transportation modes are the same for oil and biodiesel (truck, tanker and rail car).

In this study we hypothesized that biodiesel is available neat (100% biodiesel) or in blends of B20 for urban bus fleets. Neat use would tend to be supported by federal regulations that include neat biodiesel as an alternative fuel, and provide incentives to fleet managers to use neat biodiesel. Therefore, biodiesel must be available in a neat form in relatively large volumes near the retail users.

B20 is a popular alternative that bears closer examination. The biodiesel blended into diesel to make B20 will likely occur at the distribution level, similar to how ethanol is blended today with gasoline. Therefore, the biodiesel will probably be stored and blended in the retail market, probably at a tank farm where other petroleum products are stored, and again, stored in a neat form at the tank farm and blended just before delivery.

Moving very small amounts of biodiesel into markets poses some infrastructure problems. Most storage facilities for petroleum have been designed for large volumes. Also, the economies of scale associated with liquid transportation tend to show that transportation costs decline and energy efficiency improves as larger volumes of fuel are moved. Therefore, to capture economies of transportation and storage, biodiesel will tend to be moved neat in large volumes.

Most urban bus fleets are located in relatively large urban areas, which provide more opportunities for marketing biodiesel to other users. More users would tend to support larger demand and provide the opportunity to capture the economies of scale. Some biodiesel producers are targeting market development in larger cities by trying to attract large fleet customers and using those positions to expand their market sales to other customers. Blending biodiesel at refineries would not work in this study because we are examining an end use that requires neat biodiesel. Therefore, large urban markets appear to be supportable destinations for the biodiesel.

⁵⁰ The number of gallons of soy oil required to make a gallon of biodiesel is roughly the same because the glycerine component of the oil is replaced with a methanol molecule, but the volume doesn't change. Some processing losses are incurred but they are small. See the next section for more detail.

⁵¹ This hypothesis does not change even if we assume that all diesel fuel is blended with 5% biodiesel at the refinery before the blended biodiesel is moved through the existing diesel fuel distribution network. Then we may have assumed that the soy oil or biodiesel moves from the Midwest, where the soybean industry is located into regional refineries and down the river systems to Gulf coast refineries. But again, either the soy oil would have moved to the biodiesel facilities located near the refineries, or the biodiesel would have been made near the crushing plants and moved to the refineries.

This does not mean that biodiesel plants are located in the urban markets. Some biodiesel producers are part of integrated agricultural industries, owning crushing and biodiesel production facilities. Those biodiesel plants tend to be located in the soybean-producing regions. Some biodiesel producers are not associated with agricultural interests, making biodiesel out of recycled grease and other feedstocks. Those producers tend to be exploring some of the economic benefits of urban redevelopment, brown field development benefits, and similar synergies. Urban locations will also provide opportunities to reduce feedstock cost by blending soy oil and recycled grease. If we relied primarily on this distribution of biodiesel producers, we would say the industry is evenly split.

One other piece of information that may determine the balance of development is that the urban bus fleets tend to be owned and operated by local governments; those same local governments who have economic and political interests in urban redevelopment. Obtaining the supply contracts for those bus fleet customers may require a physical production presence in the urban area that leads to job creation and a stable tax base. And because those urban bus contracts may be integral components for developing a market position that provides access to other urban customers (and ultimately economies of scale), there appears to be a strong motivating force that would favor locating biodiesel facilities in urban communities.

So, having said all that, we chose to model soy oil transportation to biodiesel facilities located in urban communities, even though the future biodiesel industry may be more complex. Transportation distances are the same with either choice.

5.4.2 Modes of Transport and Distance Transported

The soy oil is being produced in the 14 major soybean-producing states. We based soybean oil transportation on a calculated U.S. average distance from the soybean crushers/soybean production regions to 14 major metropolitan areas. Fourteen metropolitan sites were chosen based on U.S. non-attainment areas of more than one million people. The 14 urban areas selected represent an average geographical distribution of U.S. cities.

National average transportation distance for soy oil transportation was calculated in a three-step process.

1. Two distances were calculated: one from the closest soybean crushing facilities to the nearest urban area; the other was based on the centroid of the major soybean-producing region to the same urban area.
2. The two distances were averaged together for each urban area.
3. The averaged urban distances were averaged together to determine a national average transportation distance for any urban area.

The information used for these calculations and the results are shown in Table 84.

The mode of transportation for the soybean oil is calculated by assuming that all the oil would be transported by train, because train transportation is more efficient than truck for distances longer than 300 miles. An additional advantage of train transportation is that the train cars themselves are used for storing the oil at the conversion facility. This practice is common in many industries.

5.4.3 Energy and Fugitive Emissions from Storage and Handling

Energy and emissions are created while loading and unloading the soybean oil.

The loading requirements are based on the electricity required to pump 1 kg of liquid as outlined in crude oil transportation modeling. We assumed that the soybean oil needs to be loaded and unloaded because the unloading is not included in the biodiesel conversion model.

We assumed that there are no fugitive emissions from loading, unloading, and transporting the soybean oil from the crusher to the biodiesel conversion facility.

Table 84: LCI Assumptions for Soy Oil Transportation

<i>City Using Biodiesel</i>	<i>Transport Distances (miles)</i>			<i>Mode of Transport (%)</i>
	<i>From Site 1</i>	<i>From Site 2</i>	<i>Avg.</i>	<i>Train</i>
	<u>Arkansas</u>	<u>Kansas</u>		
Phoenix	1260	1170	1215	100%
	<u>Iowa</u>	<u>Arkansas</u>		
LA/San Diego	1480	1470	1475	100%
	<u>Iowa</u>	<u>Arkansas</u>		
San Francisco/Sacramento	1640	1840	1740	100%
	<u>Kansas</u>	<u>Iowa</u>		
Denver	400	650	525	100%
	<u>Arkansas</u>	<u>Dallas</u>		
Dallas	300	50	175	100%
	<u>Louisiana</u>	<u>Mississippi</u>		
Houston	300	400	350	100%
	<u>Minnesota</u>	<u>Iowa</u>		
Minneapolis/St. Paul	120	240	180	100%
	<u>Illinois</u>	<u>Iowa</u>		
Chicago	175	320	247.5	100%
	<u>Ohio</u>	<u>Illinois</u>		
Cincinnati	140	320	230	100%
	<u>Ohio</u>	<u>Illinois</u>		
Cleveland	100	475	287.5	100%
	<u>Alabama</u>	<u>South Carolina</u>		
Atlanta	150	160	155	100%
	<u>Delaware</u>	<u>South Carolina</u>		
Baltimore/Washington	100	300	200	100%
	<u>Delaware</u>	<u>Illinois</u>		
New York	200	860	530	100%
	<u>Delaware</u>	<u>Illinois</u>		
Boston	360	1000	680	100%
		US Average:	571	100%

5.4.4 Soybean Oil Transport Results

Table 85 shows the LCI results for soybean oil transportation for the transport of 1 kg of soybean oil from the crushing facility to the conversion facility.

Table 85: LCI Results for Soybean Oil Transport (for kg soybean oil)

	Units	Soy Oil Transport (Total)	Railcar Loading	Rail Transportation
Raw Materials				
Coal (in ground)	kg	0.000203966	4.13E-07	0.000203553
Oil (in ground)	kg	0.00652741	1.42E-08	0.0065274
Natural Gas (in ground)	kg	0.000560541	4.53E-08	0.000560496
Uranium (U, ore)	kg	4.86E-09	9.90E-12	4.85E-09
Phosphate Rock (in ground)	kg	0	0	0
Potash (K ₂ O, in ground)	kg	0	0	0
Perlite (SiO ₂ , ore)	kg	1.48E-06	0	1.48E-06
Limestone (CaCO ₃ , in ground)	kg	3.87E-05	7.88E-08	3.86E-05
Sodium Chloride (NaCl)	kg	0	0	0
Water Used (total)	liter	0.000908433	1.27E-08	0.00090842
Air Emissions				
Carbon Dioxide (CO ₂ , fossil)	g	21.9774	0.00127989	21.9761
Carbon Dioxide (CO ₂ , biomass)	g	0	0	0
Methane (CH ₄)	g	0.00790308	3.09E-06	0.0079
Nitrous Oxide (N ₂ O)	g	0.000234333	2.36E-08	0.000234309
Carbon Monoxide (CO)	g	0.0733493	2.84E-07	0.073349
Hydrocarbons (except methane)	g	0.00109545	1.04E-08	0.00109544
Hydrocarbons (unspecified)	g	0.0254744	3.38E-08	0.0254744
Benzene	g	1.46E-06	0	1.46E-06
Formaldehyde	g	1.96E-05	6.67E-17	1.96E-05
Particulates (PM10)	g	0.00888317	0	0.00888317
Particulates (unspecified)	g	0.00464701	5.81E-06	0.00464119
Sulfur Oxides (SO _x as SO ₂)	g	0.0319926	7.30E-06	0.0319853
Nitrogen Oxides (NO _x as NO ₂)	g	0.362504	3.97E-06	0.3625
Hydrogen Chloride (HCl)	g	0.000109523	2.23E-07	0.000109301
Hydrogen Fluoride (HF)	g	1.37E-05	2.79E-08	1.37E-05
Ammonia (NH ₃)	g	2.79E-08	1.52E-12	2.79E-08
Water Emissions				
Agrochemicals (unspecified)	g	0	0	0
BOD5 (Biochemical Oxygen Demand)	g	0.00437806	5.34E-09	0.00437805
COD (Chemical Oxygen Demand)	g	0.0370451	4.52E-08	0.037045
Metals (unspecified)	g	0.000181066	3.37E-10	0.000181066
Ammonia (NH ₄ ⁺ , NH ₃ , as N)	g	0.000640132	1.32E-09	0.000640131
Nitrates (NO ₃ ⁻)	g	1.73E-07	3.53E-10	1.73E-07
Solid Waste (hazardous)	kg	1.42E-05	1.74E-11	1.42E-05
Solid Waste (nonhazardous)	kg	9.77E-05	1.51E-07	9.76E-05
Total Primary Energy	MJ	0.311422	2.03E-05	0.311402
Fossil Energy	MJ	0.311111	1.97E-05	0.311091

5.5 Soybean Oil Conversion

In modeling biodiesel production, the heart of the process for converting soybean oil to biodiesel is assumed to be a reaction known as transesterification. In this reaction, a simple alcohol such as methanol is reacted with the triglycerides in soybean oil to produce a fatty acid methyl ester (biodiesel) and glycerol. This modification of the soybean oil to make it suitable as a diesel fuel was originally proposed by researchers in South Africa (Bruwer et al. 1980). Formation of the ester was seen as a way to dramatically reduce viscosity, eliminating many of the early problems identified with the use of raw vegetable oil in diesel engines (Bruwer et al. 1980; Walton 1938; Martinez de Vedia 1944). Other approaches to producing a diesel fuel from vegetable oils and other forms of biomass exist (Shay 1993; Fleisch et al. 1995; Wong et al. 1994), but production of the fatty acid methyl ester is the only approach considered in this model.

Transesterification is not the only route to production of fatty acid methyl esters. Nor is the methyl ester the only form of ester that can be used as a fuel. An alternative approach to transesterification is to completely hydrolyze all the triglycerides to free fatty acids, and then to directly esterify these fatty acids with methanol. Transesterification has been selected for this model because it is the process of choice in all the commercial biodiesel production facilities that have come on line in Europe over the past 4 years (Korbitz 1994; Gosse 1994; Riva 1994). A number of simple alcohols have been used to produce the esters. Alcohols such as ethanol, butanol, and isopropanol have been used to make the ethyl, butyl, and isopropyl esters of the fatty acids (Kusy 1982; Nye et al. 1983; Freedman et al. 1984; Korus et al. 1993; Drown et al. 1995). However, the bulk of industrial experience, especially for fuel production, is with the use of methanol to produce methyl esters via transesterification (Korbitz 1994; Howell et al. 1995).

To ensure a realistic description of biodiesel production from soybean oil, an extensive review of available data on conversion kinetics, reactor conditions, and yields was conducted to determine assumptions for all unit operations. This review shows that ester production is old technology, whether we are talking about direct esterification of fatty acids or transesterification of triglycerides (Eckley 1954; Markley 1961; Swern 1982; Formo 1954; Eisenhard 1989). Yields of biodiesel from triglycerides are commonly in excess of 90%. Methyl esters are produced commercially today for a variety of applications, especially as intermediates in the production of detergent products. In fact, the design of the transesterification plant in our model is based on an older commercial facility located in Kansas City, Missouri. Because this facility is being offered for sale, information on the basic unit operations, mass balance, and energy requirements were available, though only in fairly sketchy form (Proctor and Gamble 1994). Practices and approaches used in this plant may not reflect the latest innovations in the industry (especially those in Europe), but they do reflect conventional practices for methyl ester in the United States. They represent a conservative basis for evaluating the energy efficiency and environmental inputs and outputs associated with this part of the biodiesel life cycle.

As we did in modeling the soybean crushing operation described in the previous section, we augmented available data from the Kansas City facility with design calculations based on chemical engineering principles. This provides for a more robust model, but it is also necessary to fill in gaps in the mass and energy balance information available from the Kansas City facility.

The mass and energy balances for production of biodiesel from soybean oil are in the form of an Excel® workbook. Mass and energy balances for each section of the plant are in interlinked worksheets. Output from the spreadsheet model is presented in the subsequent sections on soybean oil conversion.

5.5.1 Process Overview for Conversion of Soybean Oil to Biodiesel

Figure 57 shows actual output from the spreadsheet model for a soybean oil conversion facility. The model plant is broken out into six major processing sections. Tags below each section block in Figure 57

show output from a logical test indicating whether closure is achieved for the mass balance in each section. The overall material balance for the entire plant is also checked as indicated in the block at the top of the figure.

The chemistry of transesterification should yield almost exactly 1 kg of biodiesel per kg of crude soybean oil. This model facility produces 10,504 kg/h of biodiesel (equivalent to 25 million gallons per year) from 10,897 kg/h of crude oil, corresponding to a mass yield of biodiesel from oil of 96.4%. Crude oil received from the crushing operation is taken through a caustic refining step to remove free fatty acids. The soaps generated in this step are removed by washing the oil with hot water. This wash is sent to wastewater treatment. Before sending the oil to the transesterification reactor, the oil is dried to remove water, which can be detrimental to yield in the reactors. Dry, caustic-refined oil is combined with a 2:1 stoichiometric excess of methanol and a small amount of catalyst. The reaction produces methyl ester and glycerine. Unreacted methanol is recovered as extensively as possible and recycled to the reactors. A crude glycerine product (80% glycerol) is sold as a by-product.

The plant design does not include purification to USP-grade glycerine. The steps for purification of the methyl ester include countercurrent water washing to remove glycerine and methanol. The Kansas City plant used as the basis for the spreadsheet model includes a distillation step to remove unreacted and partially reacted glycerides from the product. This distillation step is not included in the model. The material balance shows that, given the assumptions for yield from the reactors, unconverted glycerides are already below the level needed to meet the proposed biodiesel fuel specification being developed by the NBB (Howell 1997).

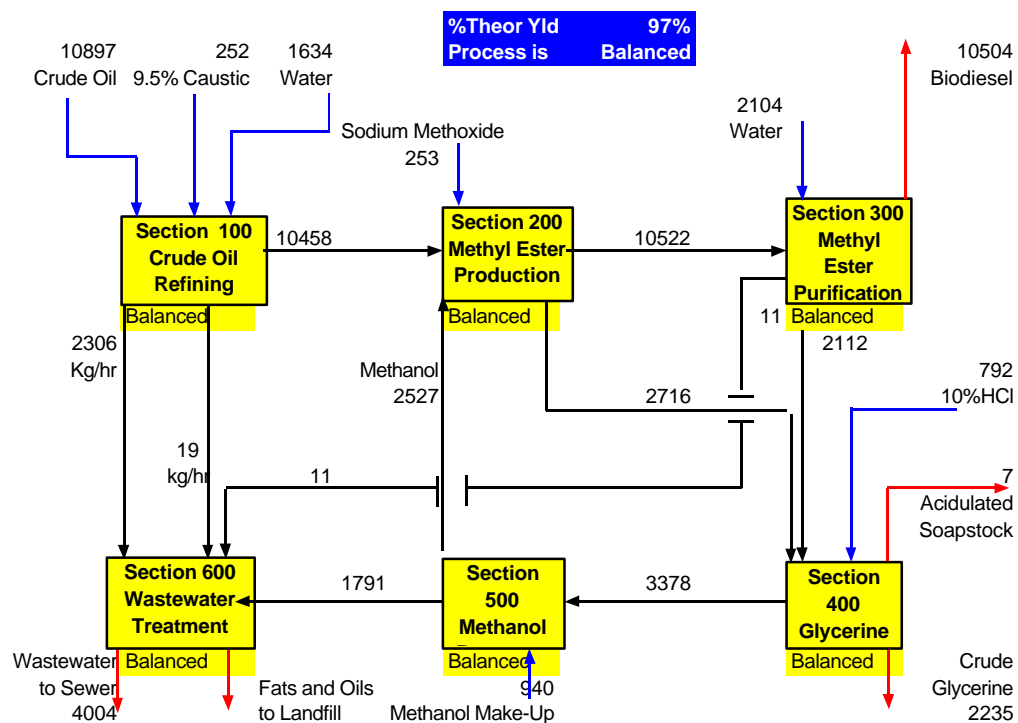
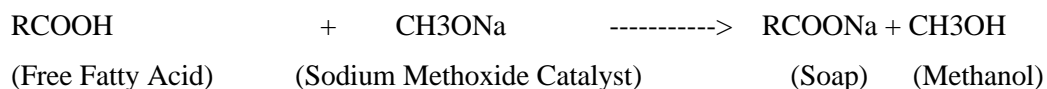

Figure 57: Overview of Process for Conversion of Soybean Oil to Biodiesel (Flows in kg/h)

The NBB's specifications are listed in Table 86. Other critical factors in the specification directly affected by processing of the crude oil are the water and sediment levels and flash point. The latter is a sensitive measure of methanol left in the fuel. Proper drying of the ester controls the former. Excessive levels of free fatty acids can affect the acid number level as well. As mentioned earlier, viscosity limits are the motivation for the chemical conversion of the soybean oil to the methyl ester.

5.5.1.1 Alkali Refining of Crude Soybean Oil

The characteristics of the crude, degummed soybean oil are taken directly from the spreadsheet model of the crushing operation (Figure 58). Content of the oil is shown in Table 87. The free fatty acids present in the oil are detrimental to the chemistry of transesterification because they can tie up catalyst through the formation of soaps, as shown in the reaction below.



In addition, soap formation can result in a more difficult phase separation of methyl ester and glycerol. To prevent this, caustic and water are added to the degummed soybean oil before carrying out the transesterification step in a process known as alkali refining. This is a well-established practice in the soybean processing industry. The conditions for this process step are based on typical industry practice (Swern 1982; Erickson 1995). The soybean oil is heated to 70°C and mixed with 14° *Baume* (9.5 wt%) caustic solution to form soap and free fatty acids.

Table 86: Tentative Biodiesel Fuel Specifications Proposed by The National Biodiesel Board

Property	ASTM Method	Limits	Units
Flash Point	93	100.0 minimum	Degrees Celsius
Water and Sediment	1796	0.050 maximum	Volume %
Carbon Residue, 100% sample	4530	0.050	Weight %
Sulfated Ash	874	0.020	Weight %
Kinematic Viscosity at 40 °C	445	1.9-1.6	Millimeter squared per second
Sulfur	2622	0.05 maximum	Weight %
Cetane	613	40 minimum	
Cloud Point	2500	By customer	Degrees Celsius
Copper Strip Corrosion	130	No 3b maximum	
Acid Number	664	0.80 maximum	Mg KOH/gm
Free Glycerine	Austrian update of GC method developed by USDA	0.020 maximum	Weight %
Total Glycerine	Same as free glycerine	0.240 maximum	Weight %

Table 87: Composition of Crude, Degummed Oil from Crushing Operation

Component	Weight %
Triglycerides	97.761%
Phosphatides	0.020%
Unsaponifiable Matter	1.5%
Free Fatty Acids	0.719%
Total	100.00%

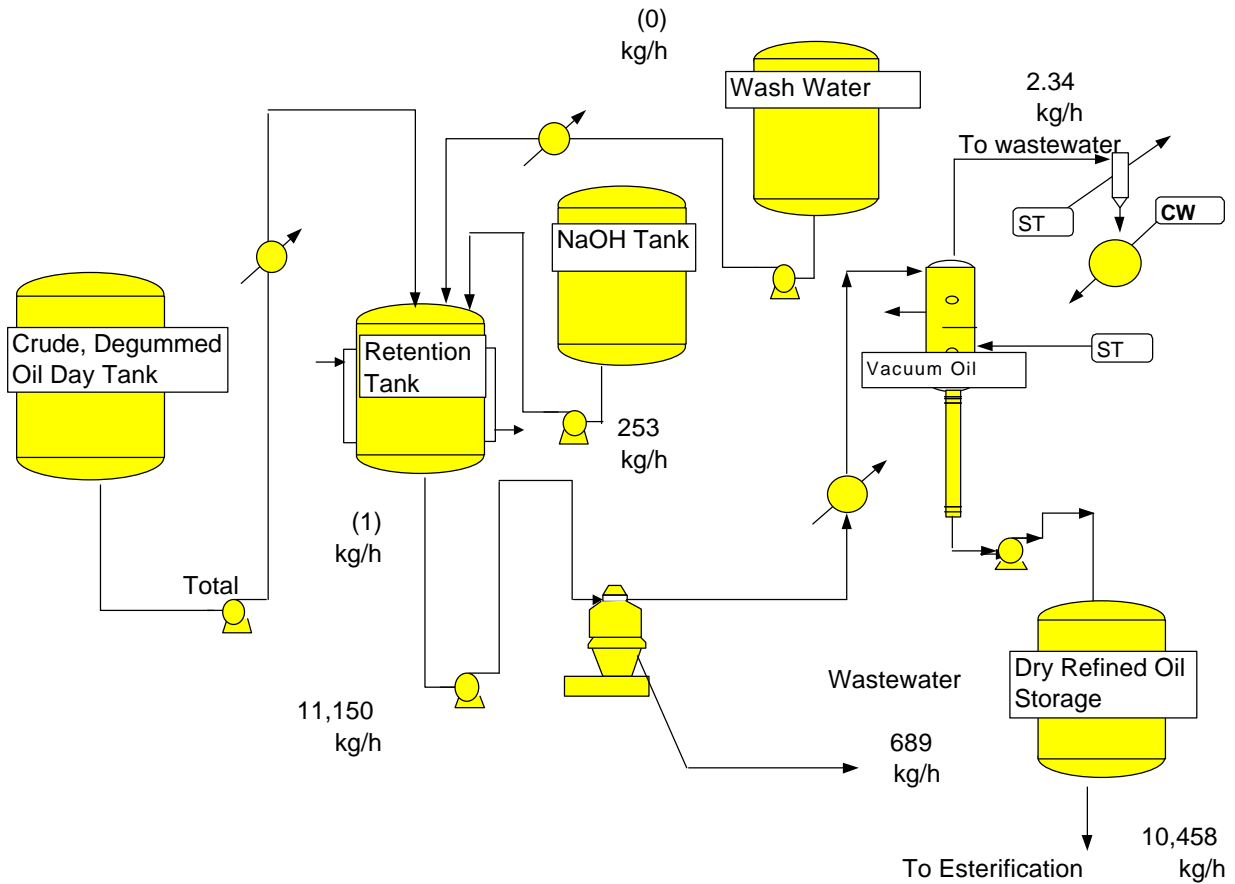
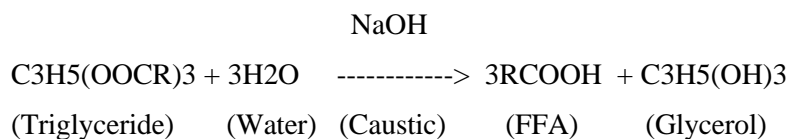

Figure 58: Alkali Refining of Crude Soybean Oil to Remove Free Fatty Acids

The measured level of free fatty acids in the oil determines the addition rate of caustic. Typically, caustic is added at a rate equivalent to a 113% stoichiometric excess.⁵² Wash water, also heated to 70°C, is added

⁵² Definition of this excess rate can be confusing. Conventions for measuring this vary. According to Erickson. (1995), this excess is defined as the amount of caustic required to neutralize the free fatty acids plus 113% of this amount. This is the convention used in the model.

at a rate of 15% of the crude soybean oil mass flow rate. Some yield loss is assumed to result from the saponification of triglycerides according to the follow reaction:



The mixture of oil, soap, and wash water is sent to a centrifuge to separate soap and water from the oil. One percent of the oil phase is assumed to be lost with the soap and water.⁵³

Of the 10,897 kg/h of soybean oil entering the refining section, 10,458 kg/h are sent to the transesterification section. This represents a total yield of 96%. A breakdown of the source of the losses is shown in Table 88. A little more than half the losses are due to removal of unwanted components (the free fatty acids and unsaponifiable matter). The remainder is loss of triglyceride. About half the triglyceride loss is due to the 1% carryover of oil in the wash water, and half is due to saponification.

Table 88: Losses Associated with Alkaline Refining of Crude, Degummed Soybean Oil

Component	Losses
Free Fatty Acids	0.719%
Triglyceride Losses	1.799%
Unsaponifiable Matter	1.485%
Total	4.00%

Steam requirements for heating and drying are summarized in Table 89. Heating of the crude oil represents three-quarters of the steam demand. All steam requirements in this report are indicated as Kcal of available latent heat⁵⁴.

Table 89: Steam Requirements for Alkaline Refining of Crude, Degummed Oil (per metric ton of Biodiesel Produced)

Unit	kcal
Crude Oil Heater	25,935.61
Wash Water Heater	7,780.68
Preheater for Vacuum Dryer	2,338.37
Vacuum Dryer	959.21
Total	37,013.87

⁵³ This is a reasonable estimate. No data were available to support this estimate. We assumed that the centrifuge is operated to maximize removal of soaps and unsaponified matter, at the expense of a small loss of triglyceride.

⁵⁴ The plant uses 150 psi steam with a latent heat content of 475.1 kcal per kg.

5.5.1.2 Transesterification

Figure 59 presents output of the transesterification section of the model. Assumptions for reactor conditions were based on a review of the literature on transesterification of vegetable oils and fats (Swern 1982; Peterson et al. 1995; Erickson 1995; Kusy 1982; Nye et al. 1983; Freedman et al. 1984; Korus et al. 1993; Drown et al. 1995). The chemistry of the reaction is as follows:

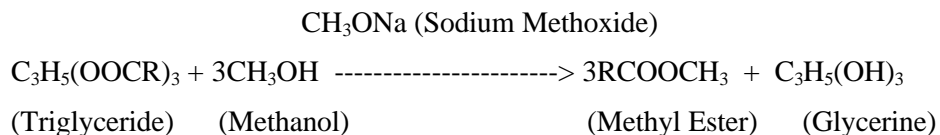

The stoichiometry of the reaction requires three molecules of methanol for every molecule of triglyceride reacted. On a weight basis, this corresponds to adding methanol at a rate of about 10% by weight per mass of oil processed. However, to obtain high yields and reasonable reaction times, an excess of methanol is usually used. In our model, this excess is assumed to be twice the stoichiometric requirement. This translates to six molecules of methanol for every molecule of triglyceride in the oil. Excess methanol remaining after the reaction is recovered later in the process. In commercial practice, a variety of base catalysts has been used to for this reaction. These include sodium hydroxide and potassium hydroxide, as well as sodium methoxide. The Kansas City facility used as a framework for our model reports the use of sodium methoxide. For consistency with this plant, we also used sodium methoxide in the model. The catalyst is present at a level of 10% in the methanol added to the reactors. For the 6:1 molar ratio of methanol to glycerides, this corresponds to a catalyst concentration in the reactor of 2.2%.

Yields of 98% have been reported for this reaction. Consistent with the Kansas City facility design, our model assumes a two-stage reactor scheme, in which 90% yields are achieved at each stage. This corresponds to an overall yield of 99%. Reported temperatures in the reactors vary from 50° to 120°C. We selected a temperature of 60°C. because the lower end of the temperature range is typical of more modern commercial facilities. These reactors require considerable mixing to achieve good contact between the methanol and oil phases. The two-phase product streams from each stage are sent to settling tanks. The oil phase containing the ester product is lighter than the aqueous phase containing the glycerol and methanol. The aqueous phase is drawn off from the bottoms of both settling tanks and sent to methanol and glycerol recovery. The oil phase from the first-stage settler is sent to the second reactor. The oil phase from the second reactor is sent to the methyl ester purification section of the plant.

The 10,455 kg/h of triglycerides entering the reactors produce 10,397 kg/h of methyl ester. This corresponds exactly to a 99% yield of ester from triglyceride on a molar basis. No other losses of oil or product occur. Potential losses can occur in the settling tanks if some of the oil phase is carried over with the aqueous phase. This design assumes that the settling tanks are being operated for maximum recovery of product, at the expense of some carryover of aqueous phase in the oil.⁵⁵ Purification of the ester removes the glycerine, methanol, and water carried over.

Steam requirements for this part of the plant are for heating of reactants to the reactor temperature of 60°C (see Table 90).

⁵⁵ We assume that 5% of the aqueous phase in the settlers is carried over with the product. This is a reasonable estimate, though no specific data were available.

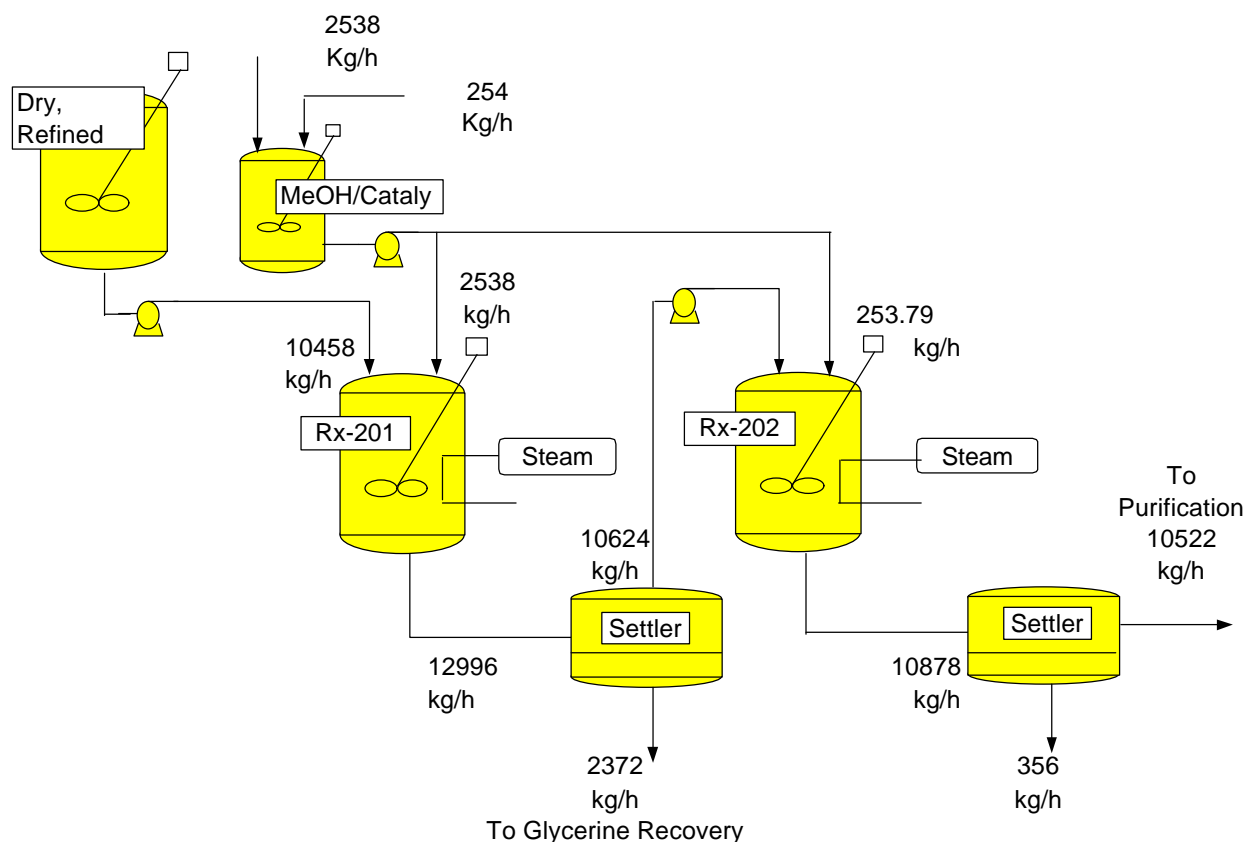

Figure 59: Transesterification Section of Biodiesel Production Facility

5.5.1.3 Methyl Ester Purification

Figure 60 shows the process steps assumed for purification of the methyl ester product. The methyl ester rich phase from the reactors is washed with water to remove glycerol, methanol, and other water-soluble components. This is done in countercurrent wash columns. Water is fed to the tops of the columns, while the methyl ester product is fed in from the bottom.

Table 90: Steam Requirements for Transesterification (Normalized per Metric Ton of Biodiesel Produced)

Unit	Kcal
First Stage Transesterification Reactor	23,186.46
Second Stage Transesterification Reactor	2,418.56
Total Steam Demand for Transesterification	25,605.02

No specific data are available for the operation of these wash columns. Information on the approach to batch water washing of methyl esters is used as a basis for establishing conditions for these columns. The steps involved in the batch process are as follows:

1. 5%-10% hot water wash. Then settle.
2. Add another 5-10% hot water wash.
3. Possible third wash if aqueous bottom layer is not clear.
4. Add another 10% hot water wash with agitation. Settle and decant.

In total, the batch process uses a water addition rate of 30%-40% of the mass flow rate of methyl ester product. For the countercurrent continuous wash, we assume complete washing can be done with only half the water addition (20%). Water enters the columns at 70°C. We assume that 10% of the wash water is entrained with the ester product, while none of the ester product is lost with the wash water. Water exiting the bottoms of the columns goes to glycerine recovery. Washed ester product is sent to a settler to separate the aqueous phase, which is also sent on to the glycerine recovery section. This settler is operated to maximize ester recovery. We assume that recovery of the ester phase is 100%, while 5% of the aqueous phase is lost to the ester phase. The ester is then vacuum dried to remove the residual water.

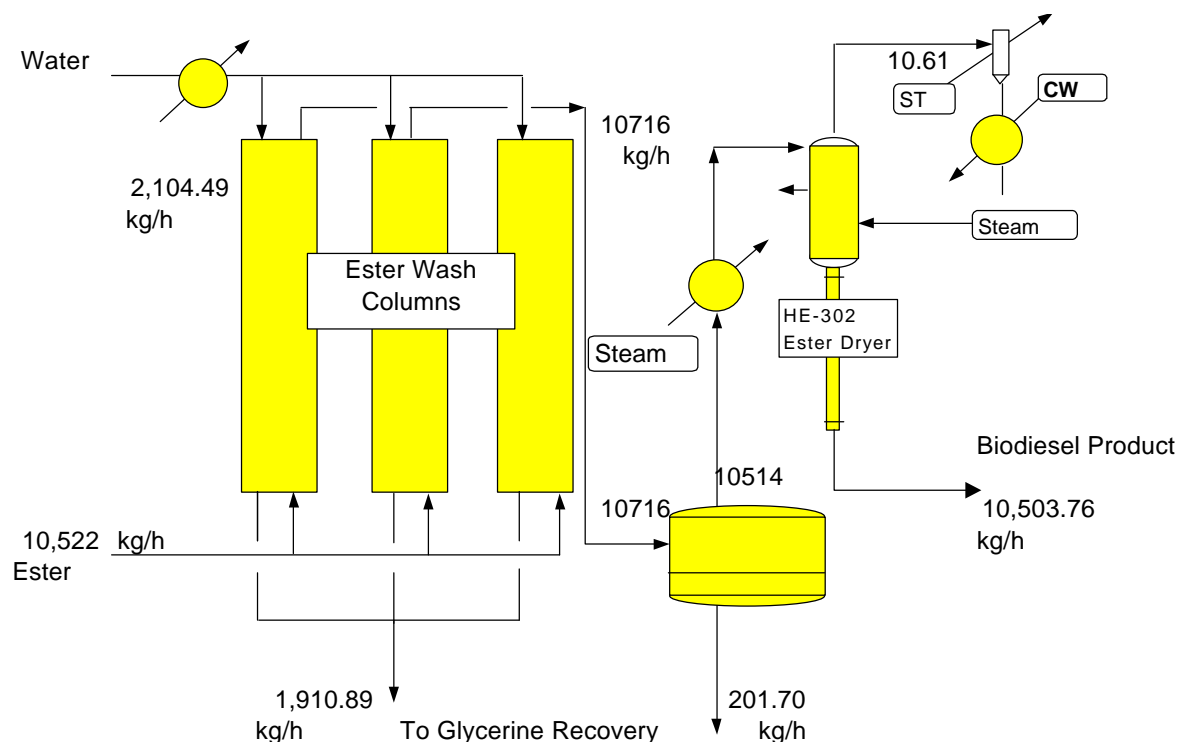

Figure 60: Methyl Ester Purification

No ester product is lost in the purification steps. Composition of the product coming out of the vacuum dryer is shown in Table 91. This composition is based on the material balance calculations for the purification section of the plant. These calculations were done to verify that the levels of glycerine (both free and total) are within the proposed limits developed by NBB.

Table 91: Composition of Final Biodiesel Product Based on Material Balance

Component	Weight %
Triglycerides	1.00%
Phosphatides	0.00%
Unsaponifiable Matter	0.02%
Methyl Ester	98.99%
Total	100.0%

The final level of glycerides is 1% by weight. The NBB standard for total glycerine is 0.24%, but this limit is glycerides measured as glycerine. When the mass fraction of total glycerides is converted to a glycerine basis, the weight percent is 0.105%, well within the limit of 0.24.⁵⁶ Free glycerine and methanol are assumed to be removed by the vacuum dryer. Vapor condensed from the dryer is sent to wastewater treatment.

Steam requirements for purification are summarized in Table 92. Steam is used in heating the ester and water before the wash columns, as well as in drying of the final product.

**Table 92: Steam Requirements for Methyl Ester Purification
(normalized per metric ton of biodiesel produced)**

Unit	Kcal
Wash Water Heater	10,017.74
Ester Heater	25,044.34
Dryer Preheater	20,040.24
Vacuum Dryer	546.12
Total	55,648.44

5.5.1.4 Glycerine Recovery

Figure 61 shows the glycerine recovery steps in the model. Glycerine-containing streams from the transesterification settlers, ester purification wash columns, and ester dryer condensate are all collected, heated, and fed to the glycerine distillation column. The design information provided for the Kansas City plant that serves as the starting point of this model indicates that this column produces a crude glycerine stream that contains 80% glycerol.

A material balance across the column is used to determine the concentration of methanol in the vapor leaving the top of the column based on the 80% glycerine composition required for the bottoms. This

⁵⁶ Converting the glyceride concentration to equivalent units of glycerine on a mass basis is done by multiplying the weight percent of glycerides times the ratio of the molecular weight of glycerine to molecular weight of triglycerides. To obtain an average molecular weight of triglycerides in soybean oil, a weighted average of the fatty acid composition of soybean oil was used. The molecular weight of glycerine is 92. The average molecular weight of triglycerides in soybean oil is 874.

translates to an overhead stream containing 47% methanol on a weight basis. In addition, the crude glycerine must be essentially methanol-free.

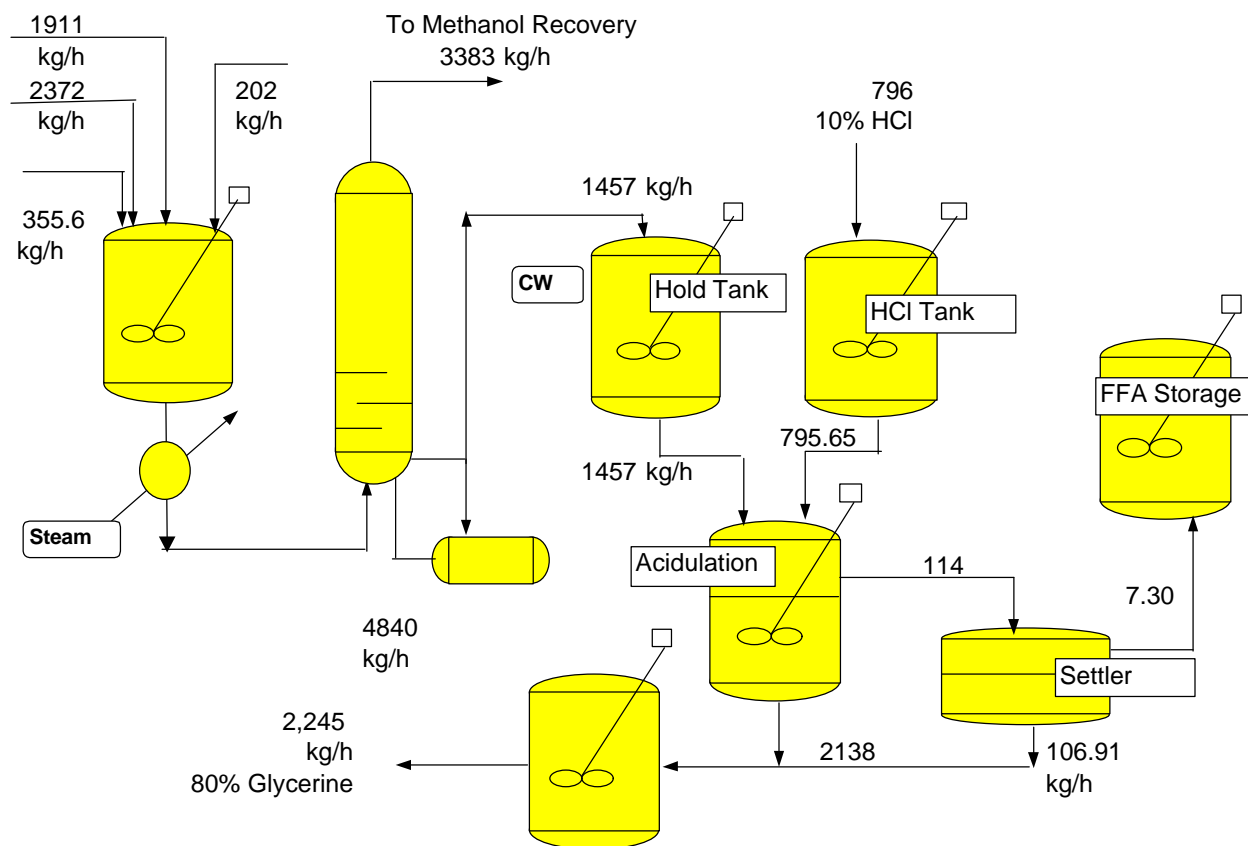

Figure 61: Recovery of Crude Glycerine By-Product

With the composition of the feed, column bottoms, and distillate set, we designed a column that operates at atmospheric pressure. ASPEN PLUS™ process simulation software was used to design the glycerine recovery column. We used the process simulator's RADFRAC™ routine to carry out rigorous tray-by-tray calculations for mass and energy balance. The software requires making an assumption for the number of theoretical trays. The design is constrained by the requirements for a crude glycerine product leaving the bottom of the column at 80% glycerine concentration. We used the number of theoretical trays to set the residual methanol concentration. A sensitivity study is done to determine the number of trays required to ensure an essentially methanol-free crude glycerine. The results of this analysis are shown in Figure 62. This figure shows that, for a column with six trays or more, methanol in the column bottoms is essentially zero.

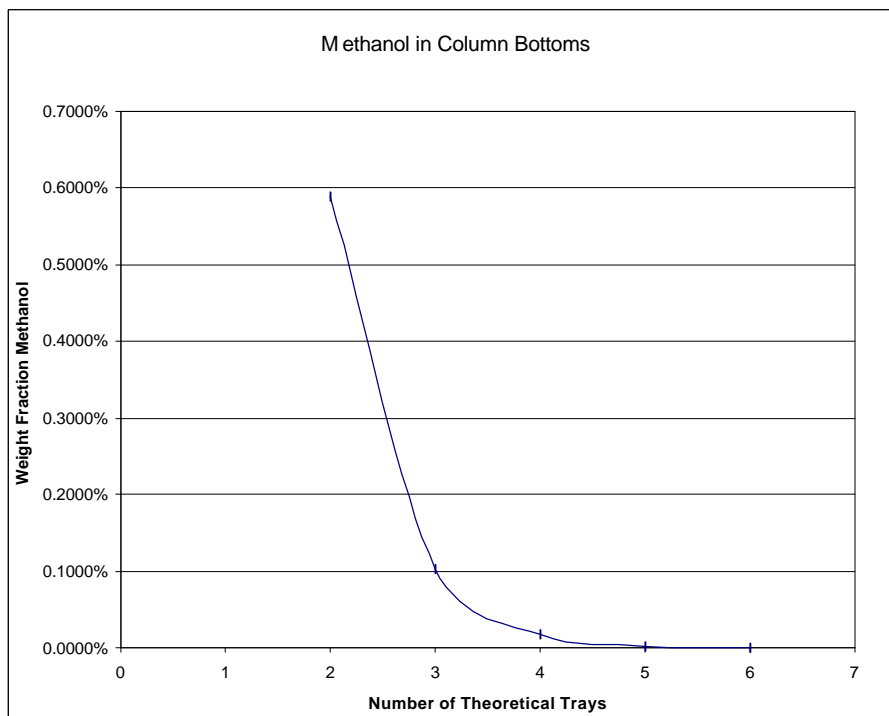

Figure 62: ASPEN PLUS™ Sensitivity Study Results:

The Effect of Column Size on Residual Methanol Concentration

Input and output summaries for the ASPEN PLUS™ six-tray column design are shown in Figure 63 and Figure 64. Steam requirements for the column’s reboiler and for the preheater are both indicated in Table 93. Preheater steam requirements are based on the sensible heat requirements for bringing the glycerine/methanol streams up to saturated liquid conditions. Distillation steam requirements are based on the calculated reboiler duty shown in Figure 64.

```

*****
**** INPUT DATA ****
*****

**** INPUT PARAMETERS ****
NUMBER OF STAGES                                6
ALGORITHM OPTION                                STANDARD
ABSORBER OPTION                                 NO
INITIALIZATION OPTION                           STANDARD
HYDRAULIC PARAMETER CALCULATIONS               NO
INSIDE LOOP CONVERGENCE METHOD                   BROYDEN
DESIGN SPECIFICATION METHOD                       NESTED
MAXIMUM NO. OF OUTSIDE LOOP ITERATIONS          25
MAXIMUM NO. OF INSIDE LOOP ITERATIONS           10
MAXIMUM NUMBER OF FLASH ITERATIONS              50
FLASH TOLERANCE                                 0.0001
OUTSIDE LOOP CONVERGENCE TOLERANCE              0.0001
**** COL-SPECS ****
MOLAR VAPOR DIST / TOTAL DIST                   1
CONDENSER DUTY (W/O SUBCOOL) MMKCAL/H           0
MASS DISTILLATE RATE      KG/HR                  3,378.00

```

Figure 63: ASPEN PLUS™ Simulation Input Summary for Crude Glycerine Column

```

*****
**** RESULTS ****
*****

*** SUMMARY OF KEY RESULTS ***

TOP STAGE TEMPERATURE      C      92.7281
BOTTOM STAGE TEMPERATURE   C      122.459
TOP STAGE LIQUID FLOW       KMOL/HR  173.216
BOTTOM STAGE LIQUID FLOW    KMOL/HR  26.937
TOP STAGE VAPOR FLOW        KMOL/HR  148.747
BOTTOM STAGE VAPOR FLOW     KMOL/HR  145.042
MOLAR BOILUP RATIO         5.38448
CONDENSER DUTY (W/O SUBCOOL) MMKCAL/H  0
REBOILER DUTY              MMKCAL/H  1.44917

```

Figure 64: ASPEN PLUS™ Simulation Results for Crude Glycerine Column

Table 93: Steam Requirements for Glycerine By-Product Recovery (normalized per metric ton of biodiesel produced)

Unit	Kcal
Glycerine Preheater	18,066.71
Distillation Columns Reboiler	137,969.48
Total	156,036.19

5.5.1.5 Methanol Recovery

The methanol and water vapor from the glycerine column are sent to a second distillation column for methanol recovery (see Figure 65). A simple graphical method is used to determine preliminary estimates for the major design parameters for the column, including reflux ratio and the number of theoretical stages in the column (Van Winkle 1967; McCabe and Smith 1976). The column is designed based on the feed conditions as specified for the vapor leaving the glycerine column. The column bottoms should contain less than 0.5% methanol; the distillate should contain less than 0.05% moisture.

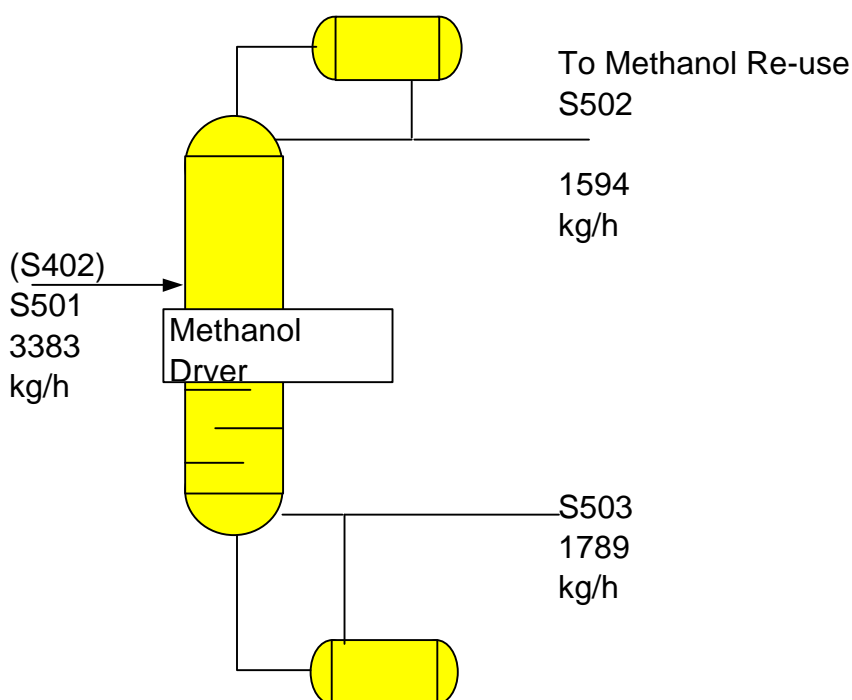

Figure 65: Methanol Recovery

To establish a more accurate optimization of reflux ratio, the estimates of reflux ratio and the number of theoretical stages from this graphical design were used as a starting point for a sensitivity study conducted using the ASPEN PLUS™ process simulation package. The results of this study are shown in Figure 66.

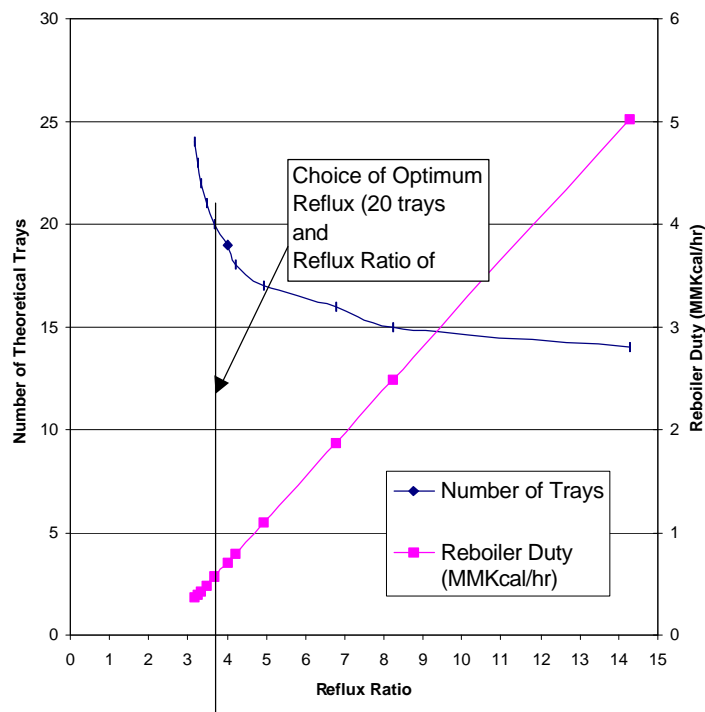

Figure 66: Selection of Optimum Reflux Ratio for Methanol Drying Column

The choice of reflux ratio strongly affects the energy requirements for the column. Larger values of reflux ratio lead to larger energy requirements, while reducing the size (and capital cost) of the column. Larger columns will reduce energy cost up to a point. At around 20 trays, increasing the column size has diminishing effect. Based on this analysis, a 20-tray column is selected. Figure 67 and Figure 68 show input and results from the ASPEN PLUS™ simulation of this column for the 20-tray case.

*** INPUT DATA ***		

*** INPUT PARAMETERS ***		
NUMBER OF STAGES		20
ALGORITHM OPTION	STANDARD	
ABSORBER OPTION	NO	
INITIALIZATION OPTION	STANDARD	
HYDRAULIC PARAMETER CALCULATIONS	NO	
INSIDE LOOP CONVERGENCE METHOD	BROYDEN	
DESIGN SPECIFICATION METHOD	NESTED	
MAXIMUM NO. OF OUTSIDE LOOP ITERATIONS		25
MAXIMUM NO. OF INSIDE LOOP ITERATIONS		10
MAXIMUM NUMBER OF FLASH ITERATIONS		50
FLASH TOLERANCE		0.0001
OUTSIDE LOOP CONVERGENCE TOLERANCE		0.0001
*** COL-SPECS ***		
MOLAR VAPOR DIST / TOTAL DIST		0
MOLAR REFLUX RATIO		6
MASS DISTILLATE RATE	KG/HR	1,587.00

Figure 67: Input Summary for 20-Tray Methanol Dryer ASPEN PLUS™ Simulation

Heating requirements for the methanol drying column are associated with the reboiler at the bottom of the column. No heat is required to treat the feed to the column, since the feed is already a saturated vapor coming from the glycerine recovery column. The steam requirements for methanol recovery are shown in Table 94.

*** SUMMARY OF KEY RESULTS ***					
TOP STAGE TEMPERATURE	C		64.4948		
BOTTOM STAGE TEMPERATURE	C		100.008		
TOP STAGE LIQUID FLOW	KMOL/HR		182.569		
BOTTOM STAGE LIQUID FLOW	KMOL/HR		98.9299		
TOP STAGE VAPOR FLOW	KMOL/HR		0		
BOTTOM STAGE VAPOR FLOW	KMOL/HR		57.8518		
MOLAR REFLUX RATIO			3.66481		
MOLAR BOILUP RATIO			0.58478		
CONDENSER DUTY (W/O SUBCOOL)	MMKCAL/H		-1.95791		
REBOILER DUTY	MMKCAL/H		0.56379		
**** MANIPULATED VARIABLES ****					
	BOUNDS		CALCULATED		
	LOWER	UPPER	VALUE		
MASS DISTILLATE RATE KG/HR	1500	2000	1595.6		
MOLAR REFLUX RATIO	1	100	3.6648		
**** DESIGN SPECIFICATIONS ****					
NO	SPEC-TYPE	QUALIFIERS	UNIT	SPECIFIED	CALCULATED
				VALUE	VALUE
1	MASS-FRAC	STREAMS: 4		5.00E-04	5.00E-04
		COMPS: WATER			
2	MASS-FRAC	STREAMS: 5		1.00E-04	1.00E-04
		COMPS: METHANOL			

Figure 68: Results of ASPEN PLUS™ Simulation for Methanol Dryer

The column bottoms are sent to waste treatment. Methanol from the top of the column is combined the fresh methanol make-up for use in the transesterification reactors.

**Table 94: Steam Requirements for Methanol Recovery
(normalized per metric ton of biodiesel produced)**

Unit	Kcal
Methanol Dryer	53,676
Total	53,676

5.5.1.6 Waste Treatment

Figure 69 shows the process flow diagram for wastewater treatment. Wastes collected from alkali refining, methyl ester purification, and methanol recovery are sent to clarifiers for removal of oil and grease. The oil and grease skimmed off the wastewater is landfilled; the remaining wastewater is sent to the municipal sewer system.

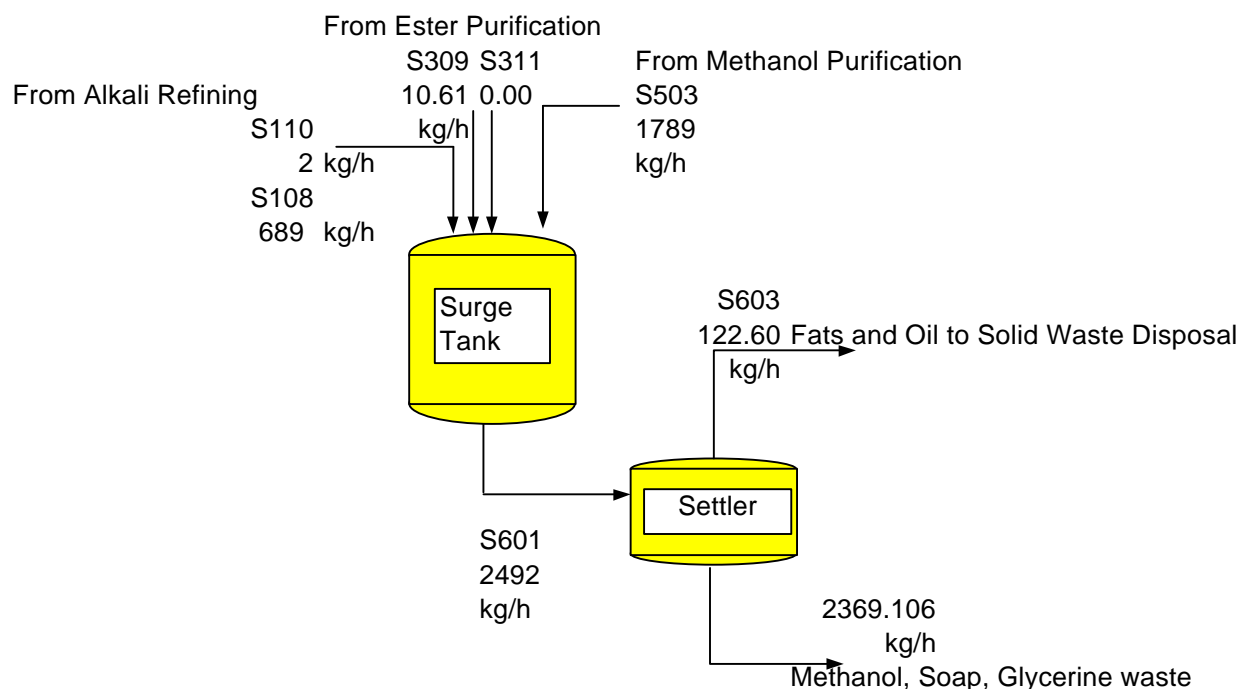

Figure 69: Wastewater Treatment for Conversion of Soybean Oil to Biodiesel

5.5.2 Analysis of Yields and Energy Balance

Figure 70 indicates yields across the major production steps for biodiesel. Losses in this process are very low. A little more than 2% of the losses occur as a result of triglycerides lost in alkali refining. Methyl ester production achieves 99% conversion of available triglycerides. Finally, no losses are seen in methyl ester purification, which involves a simple washing step

Energy requirements for the conversion of soybean oil to biodiesel include steam and electricity. Electricity requirements are taken directly from the utility demand indicated for the Kansas City facility used as the basis for our model. Electricity use is shown in Table 95. Electricity production is modeled using a generic (national average) U.S. grid.

A summary of steam requirements is shown in Table 96 and Figure 71. Steam is assumed to be produced using a natural gas-fired industrial boiler. Steam demand is greatest for glycerine recovery. Both the methanol and glycerine columns separate and recover methanol from the aqueous reactor product streams. When the energy of glycerine recovery is included with the energy requirements for methanol recovery, recycle of methanol represents 64% of the total energy demand for the conversion facility.

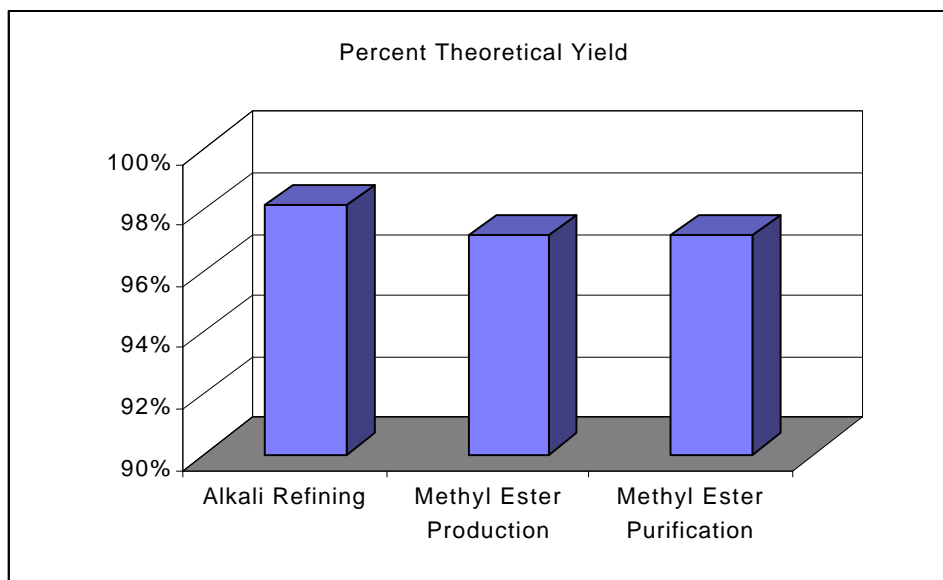

Figure 70: Yield Analysis for Conversion of Soybean Oil to Biodiesel

Table 95: Electricity Requirements for Conversion of Crude Degummed Soybean Oil to Biodiesel

Reported Annual Consumption of Electricity	5,000	MWh/yr
Reported Biodiesel Production Capacity	173	Million lb/yr
Electricity Requirements per Metric Ton Biodiesel	28.90	kWh/metric ton product

Table 96: Summary of Steam Requirements for Biodiesel Production (normalized per metric ton of biodiesel produced)

Section	Kcal
Alkaline Refining	37,013.87
Methyl Ester Production (Transesterification)	25,605.02
Methyl Ester Purification	55,648.43
Glycerine Recovery	156,036.19
Methanol Recovery	53,676.11
Waste Treatment	0.00
Total	327,979.62

The consumption of steam reported by the Kansas City facility used as a starting point for our model is shown in Table 97.

Table 97: Reported Steam Usage in Kansas City Facility Used as a Starting Point for Our Model

Mass Flow of Steam Used	225 million lb/yr
Energy Utilized in Steam	48,591,158.18 kcal/yr
Biodiesel Produced	173 million lb/yr
Steam Energy per Metric Ton of Biodiesel	617,922.24 kcal/metric ton

Our model predicts only one-half the steam demand that is indicated for the Kansas City facility. The fact that our energy balance does not match indicates that we did not have very much detail on the reactor conditions used in the facility. Nor are data on yields available. Therefore, the process design in our study used conditions and yields based on current practice as reported in the literature.

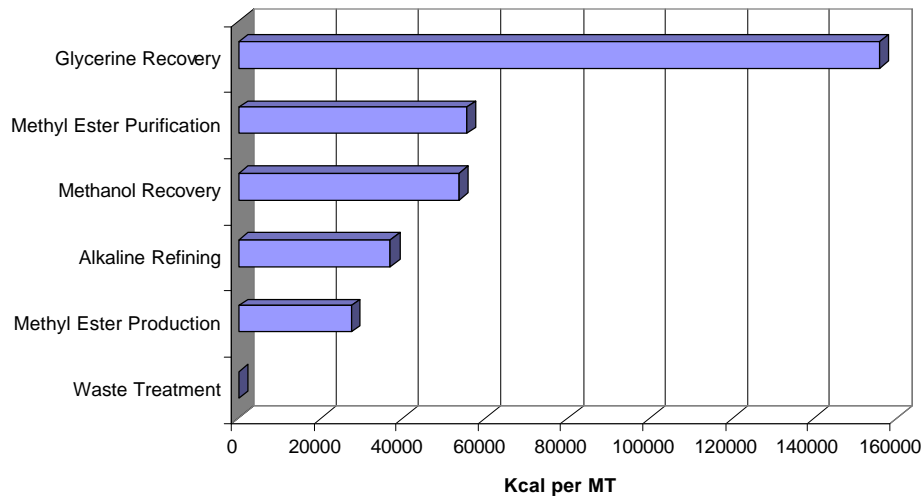

Figure 71: Distribution of Steam Requirements for Conversion of Soybean Oil to Biodiesel (normalized per metric ton of biodiesel produced)

To assess which of these numbers may best represent energy requirements for conversion of soybean oil to biodiesel, we surveyed available data on other commercial operations for biodiesel production. Most of these operations are European facilities. In order to compare these numbers on an apples-to-apples basis, we need to understand the basic process characteristics for the other commercial technologies (see Table 98 and Figure 72).

Ballestra S.p.A.'s technology⁵⁷ involves a three-step reaction using a 2:1 stoichiometric excess of methanol. They operate the reactors under vacuum at temperatures colder than 50°C. Outputs from the facility include a crude glycerine (80 wt%) coproduct and a biodiesel product made from rapeseed and

⁵⁷ "Ballestra Continuous Transesterification Process," In *Ballestra News*, November 1995. Ballestra, S.p.A., Milano, Italy, 1995.

sunflower oil. Florys S.p.A. technology⁵⁸ is a continuous production system operating at 100°C and 2.5 bar. It also produces a crude glycerine by-product. The Institut Francais du Petrole (IFP)⁵⁹ offers a commercial process that converts rapeseed to biodiesel and a crude glycerine product using mild reactor conditions of 50°C and atmospheric pressure, with sodium methoxide as the catalyst. Both Fina⁶⁰ and DeSmet⁶¹ offer high-pressure and high-temperature process technology packages.

Table 98: Comparison of Steam Requirements for Our Process Design Model and Other Available Technologies (kcal steam per metric ton of biodiesel)

Technology Source	Steam Use (kcal/metric ton)	Reactor conditions
Ballestra	96,022.71	< 50°C, atmospheric pressure, sodium methylate catalyst
Florys	166,289.74	100°C, 2.5 atm pressure, sodium methoxide catalyst
Institut Francais du Petrole	237,556.77	50° to 70°C, base catalyst
De Smet	365,837.43	High-pressure and high-temperature reactors
Fina	495,923.52	High-pressure and high-temperature reactors
NREL Model Results	327,979.62	90°C, atmospheric pressure, sodium methoxide catalyst
Kansas City Plant	617,922.24	Unspecified reactor conditions, sodium methoxide catalyst

Figure 72 ranks the process design model results relative to the technologies which operate under similar conditions and relative to the Kansas City plant data. The DeSmet and Fina steam requirements are not included because they both use high-temperature and high-pressure reactor designs.

Though the steam requirement for biodiesel production in our model is only half that of the Kansas City plant, it seems reasonable to use our model results. As Figure 72 shows, our model results are double the average of the reported steam requirements for today’s European transesterification technology.

Furthermore, details about the operation of the Kansas City facility are sparse. It seems prudent, therefore, to use the energy results for the process model since we know which assumptions support these estimates.

Table 99 presents a comparison of electricity requirements for the process design model with data available for the comparable technologies.

⁵⁸ *Process Description and Specific Consumption of Raw Materials and Utilities for the Production of Vegetable Oil Methyl-Esters (Biodiesel)*. Florys, S.p.A. brochure. Florys, S.p.A., Milano, Italy (undated).

⁵⁹ *Esterfip Process for Diese Fuel Extenders*. Institute Francais du Petrole Brochure. Institut Francais du Petrole, France (undated).

⁶⁰ *Fina Research Methanolysis Process*. Fina Research Brochure. Final Research, S.A. (undated).

⁶¹ See Howell, S. *Multi-Feedstock Biodiesel Project Phase II Final Report*, NREL Report 1997.

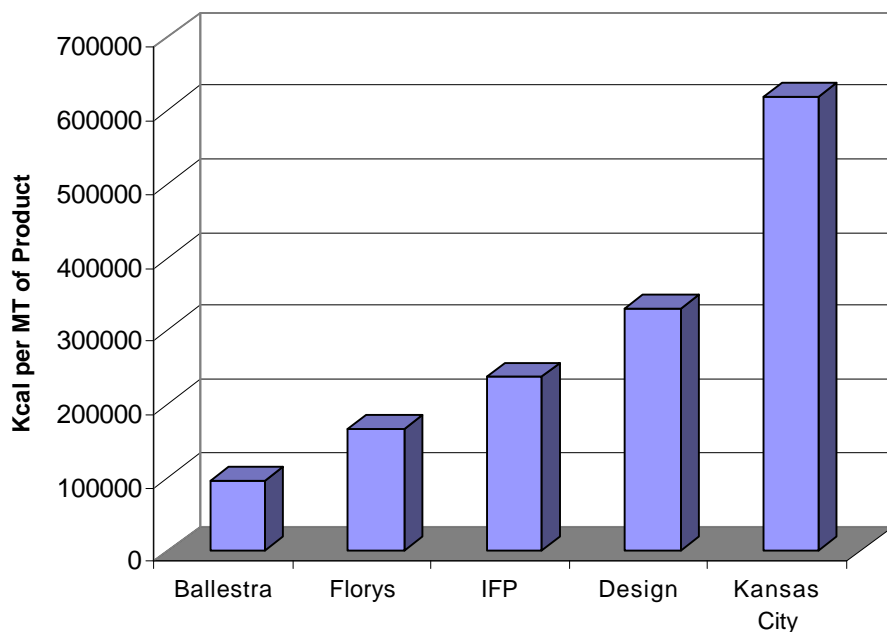

Figure 72: Ranking of Steam Requirements for Our Process Design Model and Reported Estimates for Commercial Technologies (kcal/metric ton of biodiesel)

Table 99: Comparison of Electricity Requirements for Our Process Model and for Current European Technologies

Technology Source	kWh/metric ton of Biodiesel
Ballestra	30
Florys	40
Institut Francais du Petrole	9
NREL Model	28.9

The ranking of reported electricity demand against our estimate suggests we are being reasonably conservative.

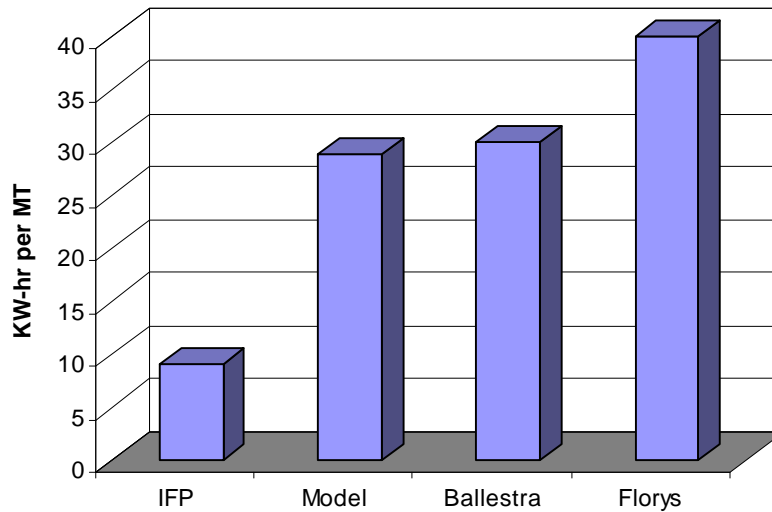

Figure 73: Ranking of Electricity Requirements for Our Process Design Model and for Current Comparable Technology

5.5.3 Overall Inputs to the Soybean Oil Conversion Facility

The biodiesel production facility has six raw material inputs, as shown in Table 100. For every 1,000 kg of biodiesel produced, 1,037 kg of crude degummed oil is required as feedstock. Approximately 90 kg of methanol is added to the system. Though methanol is added to the reactors at twice the required stoichiometric ratio, most of this excess methanol is recovered. Typically, the literature reports 100 kg of methanol for every 1,000 kg of biodiesel.

The apparently lower methanol usage shown in our inputs is due to the fact that methanol from the sodium methoxide catalyst is recovered as well. The primary use of sodium hydroxide is in alkaline refining. Hydrochloric acid (HCl) is required in acidulation of the glycerin coproduct.

Table 100: Raw Material Inputs to Biodiesel Production Facility

Material	Hourly Flow (kg/h)	Normalized Flow (kg/metric ton of Biodiesel)
Crude, Degummed Soybean Oil	10,896.64	1,037.42
Sodium Methoxide	252.71	24.06
Sodium Hydroxide (9.5%)	252.09	24.00
Hydrochloric Acid (10%)	792.26	75.43
Methanol	940.17	89.51
Water	3,738.93	355.97

Energy inputs to the facility are summarized in Table 101.

Table 101: Energy Inputs to a Biodiesel Production Facility

Type	Rate	Normalized Consumption
Electricity	303.57 kW	28.90 kWh/metric ton biodiesel
Steam	3,464,004.46 kcal/h	329,793.54 kcal

5.5.4 Overall Soybean Oil Conversion Outputs

Products from the biodiesel production facility are indicated in Table 102. The two main products are biodiesel and crude glycerine. A small amount of acidulated soapstock is produced as a result of the neutralization of fatty acids contained in the crude glycerine recovered.

Table 102: Products from a Biodiesel Production Facility

Product	Hourly Flow (kg/h)	Normalized Flow (kg/metric ton biodiesel)
Biodiesel	10,503.55	1,000.00
Acidulated Soapstock	7.27	0.69
Crude Glycerine (80% wt)	2,235.47	212.83

No air emissions are predicted in our process model, because these do not include emissions associated with combustion for steam generation. Emissions from combustion are estimated using data from the DEAM™ database.

Water and solid waste emissions are summarized in Table 103.

Table 103: Water and Solid Waste Emissions from a Biodiesel Production Facility

Classification	Component	Hourly Flow (kg/h)	Normalized Flow (kg/metric ton biodiesel)
Solid Waste	Oil and Grease	122.55	11.667
Liquid Waste	Total Wastewater	4,003.96	381.200
	Methanol	9.00	0.8572
	Water	3,660.03	348.457
	Phosphatides	2.16	0.20541
	Unaponifiable Matter	161.82	15.4058
	Soap	160.39	15.2701
	Glycerides	10.56	1.00539

5.5.5 Allocation of Life Cycle Flows for Soy Oil Conversion to Biodiesel

Soybean conversion into biodiesel produces biodiesel, glycerol, and some soapstock products. This study is concerned only with the production of biodiesel. Therefore, there needs to be a method of allocating total crushing energy use and total crushing emissions to only the production of biodiesel.

An allocation technique based on the mass output of soybean conversion is used as the baseline for this study. In order to allocate total soybean conversion environmental flows among the products on a mass output basis, the mass percent of each coproduct must be known. Table 104 outlines how this would be done, based on the output of a generic soybean conversion facility:

Table 104: Production of a Generic Soybean Conversion Facility

	Mass (k/h)	Mass (%)
Biodiesel:	10,503.5	82 %
Glycerine:	7.3	0.06 %
Soapstock:	2,235.5	18 %
Total:	12,746.3	

5.5.6 Soybean Conversion Results

Figure 74 presents a schematic of the system for conversion of soybean oil to biodiesel modeled with TEAM™. Table 105 shows the LCI results for soybean oil conversion for the production of 1 kg of biodiesel.

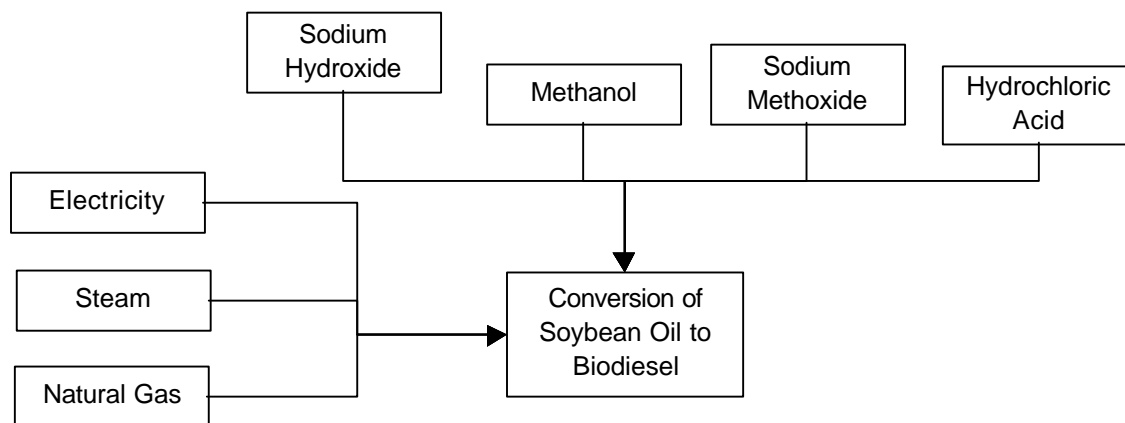

Figure 74: Schematic of Inputs to TEAM™ Model for Conversion of Soybean Oil to Biodiesel

Table 105: LCI Results for Soybean Oil Conversion (for 1 kg of biodiesel)

	Units	Soybean Oil Conversion	Steam Production	Electricity Production: US Average	Methanol Production	Sodium Methoxide Production	Sodium Hydroxide Production	Hydrogen Chloride Production	Soybean Conversion
Raw Materials									
Coal (in ground)	kg	0.0118507	4.97E-08	0.00590285	0.00118846	0.00300157	0.00035979	0.00139796	0
Oil (in ground)	kg	0.00203498	6.48E-08	0.000203089	4.10E-05	0.00114872	0.00014613	0.00049597	0
Natural Gas (in ground)	kg	0.0946834	0.0281715	0.000647469	0.05484	0.0103907	0.00016527	0.00046848	0
Uranium (U, ore)	kg	1.74E-07	1.19E-12	1.41E-07	2.85E-08	4.54E-09	0	0	0
Phosphate Rock (in ground)	kg	0	0	0	0	0	0	0	0
Potash (K ₂ O, in ground)	kg	0	0	0	0	0	0	0	0
Perlite (SiO ₂ , ore)	kg	0	0	0	0	0	0	0	0
Limestone (CaCO ₃ , in ground)	kg	0.00167708	9.43E-09	0.00112559	0.000226621	0.000190292	1.97E-05	0.00011485	0
Sodium Chloride (NaCl)	kg	0.0172361	0	0	0	0.00866427	0.00110847	0.0074634	0
Water Used (total)	liter	0.558377	7.99E-09	0.000181251	0.147549	0.101334	0.00995741	0.00603847	0.293318
Air Emissions									
Carbon Dioxide (CO ₂ , fossil)	g	170.082	82.9689	18.2873	35.8645	23.2311	2.10421	7.62574	0
Carbon Dioxide (CO ₂ , biomass)	g	0	0	0	0	0	0	0	0
Methane (CH ₄)	g	0.500959	0.136914	0.0440873	0.274471	0.0454863	0	0	0
Nitrous Oxide (N ₂ O)	g	0.00112695	0.000379465	0.000337674	0.000349276	6.05E-05	0	0	0
Carbon Monoxide (CO)	g	0.0618712	0.0276957	0.00405177	0.0113161	0.0124397	0.00131513	0.0050528	0
Hydrocarbons (except methane)	g	0.00156164	0.000948278	0.000148282	0.000390616	7.45E-05	0	0	0
Hydrocarbons (unspecified)	g	0.14588	5.66E-07	0.000482341	9.82E-05	0.0954694	0.0122119	0.0376176	0
Benzene	g	0	0	0	0	0	0	0	0
Formaldehyde	g	1.17E-12	7.90E-17	9.52E-13	1.92E-13	3.06E-14	0	0	0
Particulates (PM10)	g	0.00280072	0.0019907	0	0.000676549	0.000133463	0	0	0
Particulates (unspecified)	g	0.17608	5.05E-05	0.0830695	0.0168216	0.0482042	0.00582414	0.0221103	0
Sulfur Oxides (SO _x as SO ₂)	g	2.45438	0.638761	0.104258	1.26082	0.355926	0.0187876	0.0758267	0
Nitrogen Oxides (NO _x as NO ₂)	g	0.408812	0.112734	0.0567286	0.0643086	0.117432	0.013527	0.0440815	0
Hydrogen Chloride (HCl)	g	0.00755151	2.68E-08	0.00318532	0.000641319	0.00230493	0.00028181	0.0011381	0
Hydrogen Fluoride (HF)	g	0.000491102	3.35E-09	0.000398165	8.02E-05	1.28E-05	0	0	0
Ammonia (NH ₃)	g	2.68E-08	1.55E-11	2.17E-08	4.40E-09	7.01E-10	0	0	0
Water Emissions									
Agrochemicals (unspecified)	g	0	0	0	0	0	0	0	0
BOD5 (Biochemical Oxygen Demand)	g	0.000162724	3.36E-08	7.63E-05	1.54E-05	4.65E-05	5.64E-06	1.89E-05	0
COD (Chemical Oxygen Demand)	g	0.0010744	2.84E-07	0.000645328	0.000130469	0.000211693	2.44E-05	6.22E-05	0
Metals (unspecified)	g	0.00173099	1.65E-09	4.82E-06	9.73E-07	0.00102812	0.00013151	0.00056557	0
Ammonia (NH ₄ ⁺ , NH ₃ , as N)	g	2.33E-05	4.97E-09	1.88E-05	3.80E-06	6.06E-07	0	0	0
Nitrates (NO ₃ ⁻)	g	6.22E-06	4.25E-11	5.05E-06	1.02E-06	1.62E-07	0	0	0
Solid Waste (hazardous)	kg	7.64E-07	1.09E-10	2.48E-07	5.02E-08	3.02E-07	3.76E-08	1.26E-07	0
Solid Waste (nonhazardous)	kg	0.0141251	1.15E-07	0.00216033	0.000435141	0.00115602	0.00013903	0.00062043	0.00961401
Total Primary Energy	MJ	39.9088	1.46493	0.290053	2.90332	0.773746	0.037406	0.13045	34.3089
Fossil Energy	MJ	5.57241	1.46493	0.281005	2.9015	0.763029	0.0360721	0.125884	0
Fuel Energy per kg of Biodiesel	MJ	2.95884	1.46493	0.290053	0.625141	0.410869	0.037406	0.13045	0

5.6 Biodiesel Transport

The transport of biodiesel from the conversion facility to the point of use is estimated assuming the conversion facility is located close to the point-of-use. For more information, see the previous section on soy oil transportation. This section contains the assumptions and descriptions of the data used to model biodiesel transportation to end-use.

5.6.1 Modes of Transport and Distance Transported

We assumed that both B100 and B20 were transported a maximum distance of 100 miles by heavy-duty tank trucks from the production facility to the point of end-use, in this case the storage facility at the bus fleet refueling site. We felt that this distance was long enough to encompass situations in which the biodiesel facility may be located on the opposite side of a very large urban area from the bus refueling site. This distance is also long enough to encompass transporting biodiesel to a tank farm and moving the B20 to the bus refueling site.

In addition, 100 miles is consistent with the distance used to transport diesel fuel from the refinery to the urban bus refueling center. The transportation models from DEAM™ are used to model truck transportation energy requirements and emissions.

5.6.2 Energy and Fugitive Emissions from Storage and Handling

In addition to the energy requirements and subsequent emissions from the actual modes of transportation (truck diesel use and emissions), energy and emissions are also created while loading and unloading the biodiesel.

The pumping requirements for biodiesel are calculated in the same method as for crude oil pumping. We assumed that the electricity requirements are the same for different types of liquids. Electricity is assumed to come from a generic (national average) U.S. grid. The physical characteristics of biodiesel and diesel fuel are very similar so no significant biases are expected to be introduced here.

The fugitive emissions from loading, unloading, and transporting the biodiesel are calculated using the same formulas as for the crude oil fugitive emissions. The formulas are modified based on the biodiesel properties. The vapor pressure of the biodiesel at 160°C is estimated based on the vapor pressure of methyl oleate which is one of a variety of fatty acid compounds in biodiesel. The fatty acid profile of biodiesel is determined by the feedstock oil, and soy oil contains oleic acids as well as other fatty acids.

Fugitive tank emissions from the storage of biodiesel at the conversion facility are included in the biodiesel conversion model. Fugitive tank emissions from the storage of biodiesel at the urban bus refueling location are assumed to be negligible. Biodiesel has a higher flash point compared to diesel fuel, and thus is less volatile. Actual volatile emissions have not been documented for biodiesel.

Figure 75 represents how the emissions from biodiesel transportation are modeled in this project.

5.6.3 Biodiesel Transportation Results

Table 106 shows the LCI results for the transporting 1 kg of biodiesel from the conversion facility to the point of use.

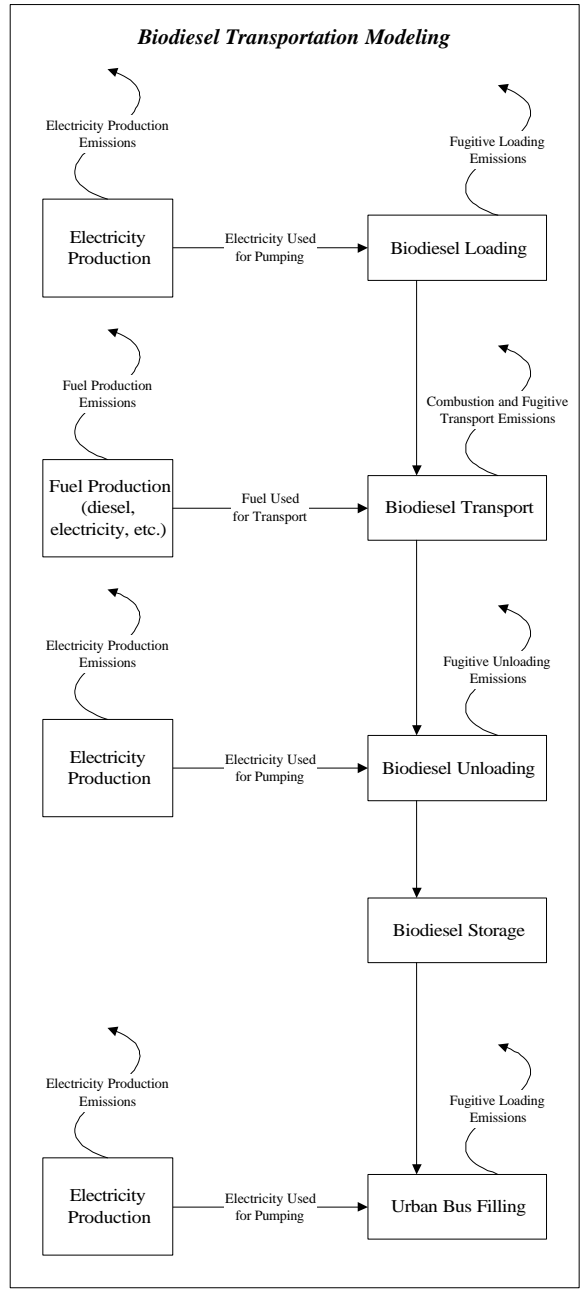

Figure 75: Biodiesel Transportation Modeling

Table 106: LCI Results for Biodiesel Transportation (for kg of biodiesel)

	Units	Biodiesel Transportation	Truck Loading	Truck Transport
Raw Materials				
Coal (in ground)	kg	0.000106422	6.20E-07	0.000105802
Oil (in ground)	kg	0.00339281	2.13E-08	0.00339279
Natural Gas (in ground)	kg	0.0002914	6.80E-08	0.000291332
Uranium (U, ore)	kg	2.54E-09	1.49E-11	2.52E-09
Phosphate Rock (in ground)	kg	0	0	0
Potash (K ₂ O, in ground)	kg	0	0	0
Perlite (SiO ₂ , ore)	kg	7.71E-07	0	7.71E-07
Limestone (CaCO ₃ , in ground)	kg	2.02E-05	1.18E-07	2.01E-05
Sodium Chloride (NaCl)	kg	0	0	0
Water Used (total)	liter	0.000472194	1.90E-08	0.000472175
Air Emissions				
Carbon Dioxide (CO ₂ , fossil)	g	11.3047	0.00191984	11.3028
Carbon Dioxide (CO ₂ , biomass)	g	0	0	0
Methane (CH ₄)	g	0.00405364	4.63E-06	0.00404901
Nitrous Oxide (N ₂ O)	g	0.00112314	3.54E-08	0.0011231
Carbon Monoxide (CO)	g	0.0383396	4.25E-07	0.0383392
Hydrocarbons (except methane)	g	0.00825505	1.56E-08	0.00825503
Hydrocarbons (unspecified)	g	0.00447132	5.18E-08	0.00447127
Benzene	g	7.61E-07	0	7.61E-07
Formaldehyde	g	1.02E-05	1.00E-16	1.02E-05
Particulates (PM10)	g	0.0128168	0	0.0128168
Particulates (unspecified)	g	0.0024211	8.72E-06	0.00241238
Sulfur Oxides (SO _x as SO ₂)	g	0.0166609	1.09E-05	0.01665
Nitrogen Oxides (NO _x as NO ₂)	g	0.106355	5.96E-06	0.106349
Hydrogen Chloride (HCl)	g	5.71E-05	3.34E-07	5.68E-05
Hydrogen Fluoride (HF)	g	7.14E-06	4.18E-08	7.10E-06
Ammonia (NH ₃)	g	1.45E-08	2.28E-12	1.45E-08
Water Emissions				
Agrochemicals (unspecified)	g	0	0	0
BOD5 (Biochemical Oxygen Demand)	g	0.00227562	8.01E-09	0.00227561
COD (Chemical Oxygen Demand)	g	0.0192552	6.77E-08	0.0192551
Metals (unspecified)	g	9.41E-05	5.06E-10	9.41E-05
Ammonia (NH ₄ ⁺ , NH ₃ , as N)	g	0.000332726	1.98E-09	0.000332725
Nitrates (NO ₃ ⁻)	g	9.05E-08	5.30E-10	9.00E-08
Solid Waste (hazardous)	kg	7.41E-06	2.61E-11	7.41E-06
Solid Waste (nonhazardous)	kg	5.09E-05	2.27E-07	5.07E-05
Total Primary Energy	MJ	0.16189	3.05E-05	0.161859
Fossil Energy	MJ	0.161727	2.95E-05	0.161698

This page intentionally left blank